

LOCKS

Beyond the **need** for locks, which is obvious, many considerations need to be made as to the type of lock, their purpose, and the safety issues involved in someone getting in **and** out of a locked door or window in case of an emergency such as a fire or natural disaster. The overall **best** lock for the purposes of securing your residence is a **single-cylinder deadbolt lock** that opens from the outside with a key and from the inside **with** a simple **thumb** pinching and **turning** with your hand and without a key. Unfortunately, these locks are not common in most homes.

We will first examine the various ways in which a burglar may open a door:

- These are limited only by the ability of the burglar and the amount of time he has at his disposal. Remember, delaying a burglar is one of your best deterrents. There are many ways that a lock can prove meaningless to a burglar who:
 - Finds the door unlocked.
 - Has a key, from the previous owners or tenants, or finds it under door mats, in flower pots or the mail box, or over the door.
 - Removes or breaks glass in the door and reaches inside and opens the door.
 - Jimmys or pries the door open with a crowbar or other tool.
 - Gets the victim to open the door and foolishly relies on a useless chain latch.

- Splits or spreads the door frame by kicking in the door, usually at the lock area, or by the use of tools.
- Finds a door with plywood panels which can easily be kicked in, the door unlatched or simply crawls through the opening.
- Uses a pipe wrench, hammers the door knob or pulls the key cylinder plug with a slide hammer dent puller.

Most of these ways can be prevented with a little common sense. Not all, though, and here is a rundown of locks:

Spring Latch Lock

If you use this as the sole means of security, you might as well not even close your door.

As you close the door, the latch springs into place. A simple shim is placed between the door and the frame, causing the latch to retract and the door to open. The technique is so simple the most inexperienced burglar can almost walk through the door.

A deadbolt lock must be added to provide security. A spring latch lock by itself is virtually worthless for security.

Cylinder (Key in the Knob) Lock

These are not adequate for exterior locks. They are best used for interiors and privacy, such as closets and bathrooms.

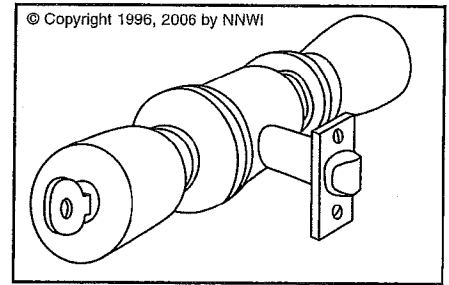

Easily can be opened with credit cards, a dent puller or pipe wrench.

Deadlatch Lock

These locks are equipped with a deadlatching or tripper pin that is attached to the bolt.

When the door is closed, this pin is depressed. With the pin in this position, the bolt is immobilized. This lock is somewhat better than the spring latch lock, it is still vulnerable to prying, twisting or pounding.

A deadbolt lock must be added to provide security.

Single Cylinder Horizontal Deadbolt

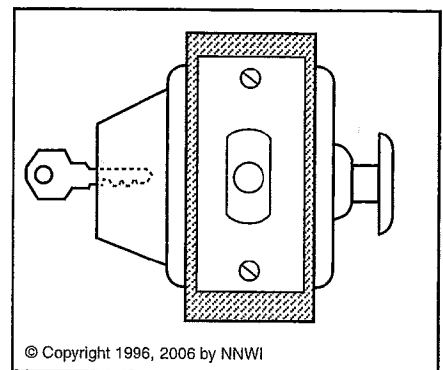

Keyed on the outside of the locking cylinder with a thumb turning latch on the inside.

Ideally this lock would have a minimum 1" throw of the deadbolt, the deadbolt would have a case hardened steel insert in it to prevent cutting, the cylinder guard would be of case-hardened steel, tapered and free turning.

The thumb turn on the inside eliminates the need for a key, as is the case with a Double Cylinder Deadbolt Lock. This is great for safety, especially in case of a fire.

This lock, with a solid core door and no nearby windows is your best security.

However, if your door has a window or there is a window within arms reach of the thumb turning latch, your security is compromised. Weak doors coupled with this lock also compromise security.

Double Cylinder Horizontal Deadbolt

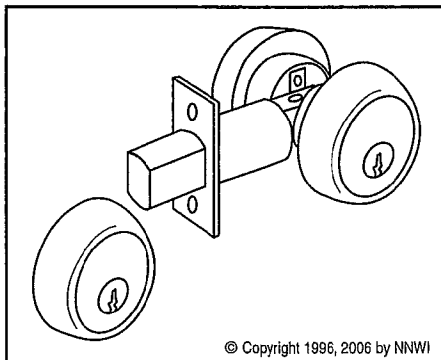

Keyed on the inside and the outside of the locking cylinder.

Only appropriate for non-residential settings, such as businesses or toolsheds.

Does not allow easy exit to burglars who have hidden in a business until after-hours.

Many building codes make this type of lock unacceptable for residences because of the need for a key in case of emergency exiting.

Double Locking Deadbolt

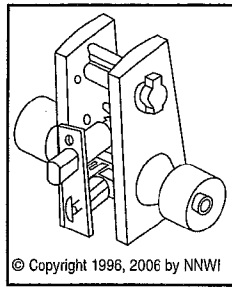

that resists sawing or prying.

The lock mechanism is protected by an armor plate under the ornamentation, making it resistant to drilling, sawing or piercing.

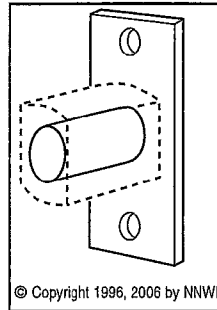

When the door is locked, the outside knob is free-spinning, so that it is impossible to get leverage on it to force or twist it.

The recessed cylinder discourages forceful entry.

Single Cylinder Vertical Deadbolt (also known as a Rim Lock)

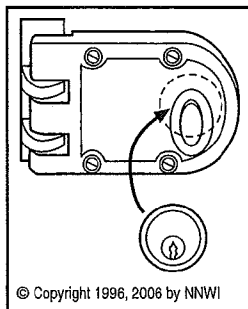

Keyed on the outside with a thumb turn on the inside.

Extremely resistant to prying or cutting.

Mounted on the surface of the door as opposed to single or double cylinder deadbolts which are mortised.

If your door has a window or there is a window within arms reach of the thumb turning latch, your security is compromised. Weak doors coupled with this lock also compromise security.

Buttress-type Lock

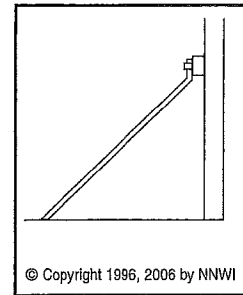

If the frame can not be strengthened or reinforced, as in an older building, this type lock should be used with

a long steel bar that sticks into a floor receptacle and wedges against the inside of the door. In this way, the strength of the door is being used instead of the frame.

It is important that the bottom of the door fits closely to the floor to avoid the steel bar being removed from the floor receptacle by an intruder.

Cremone Bolt

A device of surface application that by a turn of a knob or lever handle locks the door or sash into the frame, top and bottom.

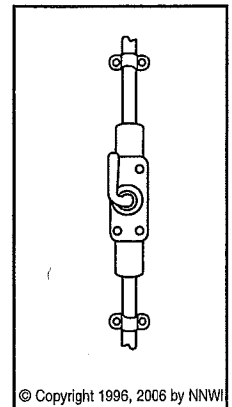

© Copyright 1996, 2006 by NNWI

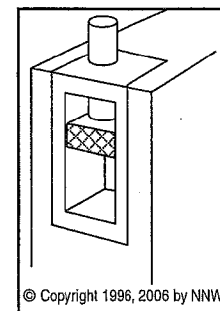

© Copyright 1996, 2006 by NNWI

Flush Bolt

Very similar to cremone bolt except that the bolts are operated independently, top and bottom. Is usually used for double

doors, with bolt installed on the inactive door. When applied, bolt is flush with the face or edge of the door.

Flush bolts offer additional security since the intruder cannot get at these devices to tamper with them if the doors are locked.

Cross Bar

Useful for a door which is seldom used or is not required as an emergency exit.

Heavy hooks holding a heavy cross bar provide excellent security when padlocked. If the door is never used, the cross bar can be bolted to the hooks.

The cross bar should be secured to the hooks so an intruder can not easily use the door as an exit, or pry the crossbar off by slipping a tool between the door frame and the door in order to lift the cross bar.

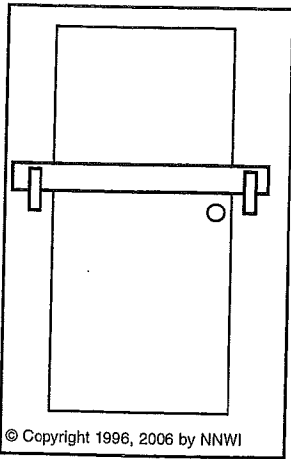

Strike Plate

A reinforced strike plate is necessary for good locks to perform well. Strike plates

can be reinforced by using screws long enough to reach past the trim and into the studs, at least 3"-5". The strike plate should have at least four screw holes, and screws run through each hole into studs.

An added precaution would be the attaching of a piece of heavy-gauge sheet metal to the door frame for about 16" This will reinforce the lock area and

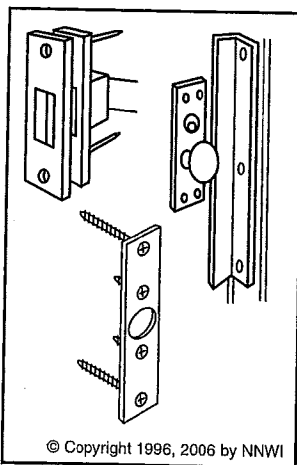

make it more difficult for someone to overcome the lock by kicking the door in.

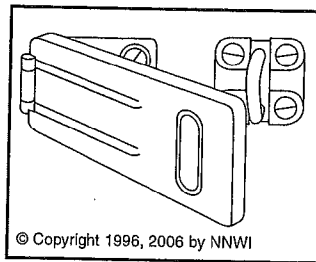

Hasps

Hasps are fastening devices consisting

of a loop and a slotted hinged plate. The placement of the hasp high up on the doorway will make it more difficult for an intruder to manipulate the lock going through the loop. Hasps should be very securely bolted or secured into place, so that the heads of the screws are completely covered when the hasp is closed.

Padlocks

A good padlock should be of case-hardened steel, have heel and toe locking features and constructed so the key can not be removed unless the padlock is in the locked (closed) position. Identification numbers should be recorded and then obliterated on the lock casing.

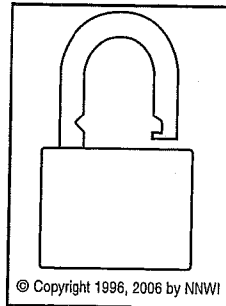

Panic Bars

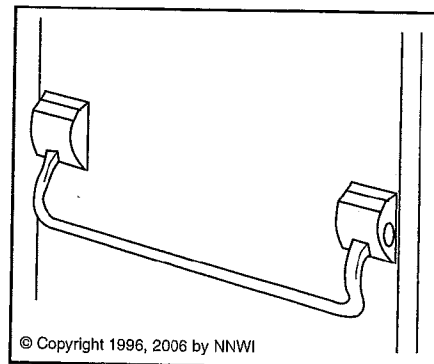

Where a doorway in a public area must be available for an emergency exit, but not for

entrance, it can best be secured with a panic bar. There is no lock visible on the outside. A simple push on the bar from the inside actuates a Cremone bolt (top and bottom) or a center latch, allowing the door to swing outward.

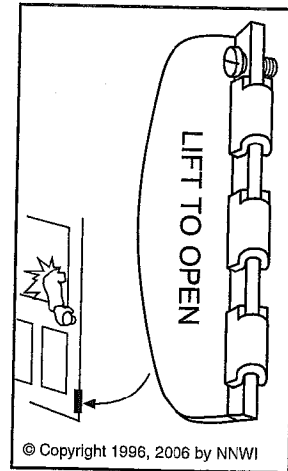

Flip or Nib Lock

This type of lock, when installed properly with wood screws of at least 1-1/2" length

and located out of reach of any windows and small children, provides good additional security. A flip or nib lock has two sections, one attached to the door and one to the frame. A metal flap extends out from the frame and swings into a locked position on the door.

Common Chain Locks - Last and Definitely Least!

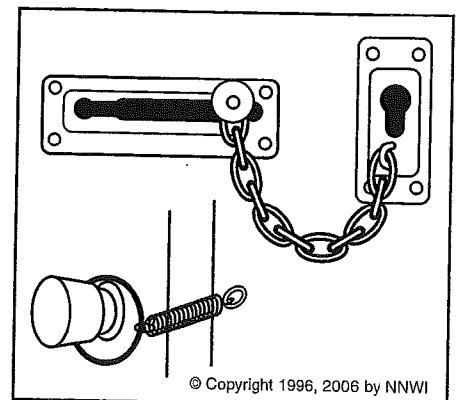

Easily defeated with a kick or strong push, the chain is usually very weak and the screws holding the lock are almost always too short. Extra-heavy duty varieties may be available, and if properly installed could be effective. Not recommended.

DOORS

Solid Core Doors

This type of door is solid wood throughout. This door can be distinguished from a hollow core door by its weight and solid sound when knocked on. Because there is no glass in the door, it is recommended that a

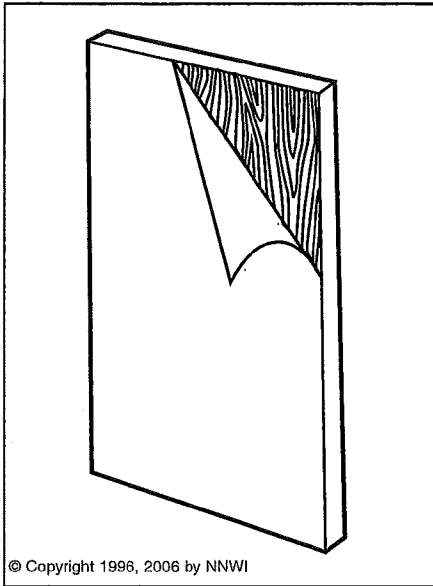

wide angle viewer, with good peripheral vision (180 to 200 degrees) be installed to observe callers. With a single-cylinder, horizontal deadbolt lock installed, **this is your best choice for external door security.**

Metal Doors

More commonly found in commercial businesses and industrial locations, they consist of a medium gauge sheet metal welded together and pre-drilled for spring-latch locks, but not usually for an auxiliary deadbolt lock. If they can be obtained with a drill hole to accommodate a horizontal deadbolt lock, they would be second among the choices for security. Usually more expensive than solid core doors, they have been known to bend inward under sufficient impact rendering the lock useless.

Panel Doors

These doors are basically solid in the main structure of the door, but they are compromised

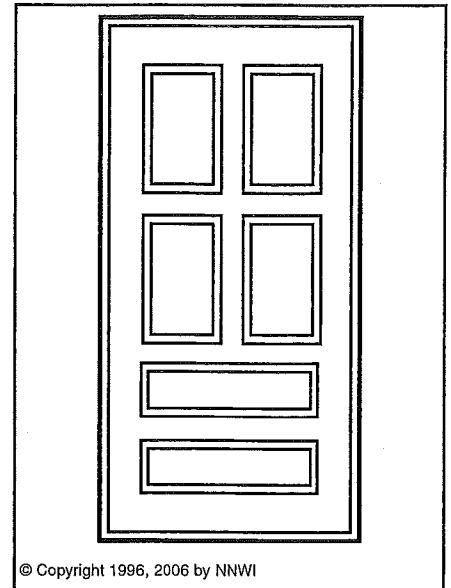

by varying designs of beveled panels, which create thinner portions of the door, which are vulnerable to breaking through. If this door is used for exterior purposes, it is advised that the panels be at least 1/2" in thickness or reinforced to an equivalent strength. These are not as strong as solid core doors.

French Doors

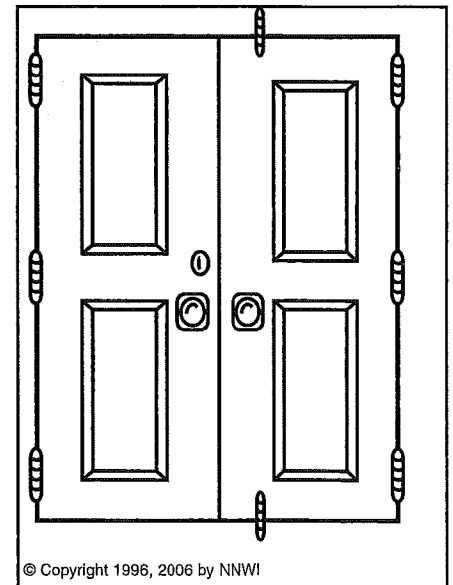

These doors are very weak. They often have glass, are very attractive but they offer no degree of security. They can be compromised with a little pushing or kicking. A minimal amount of

KEYS

In over half of all burglaries in the nation, entry into the house was **not** forced. Doors and windows were left open and **KEYS WERE AVAILABLE.**

Here are important tips on keys:

- 1** Never hide your key outside. Burglars know all the hiding places.
- 2** Never carry identification tags on your key ring or holder.
- 3** If you valet park your car, use a separate key for parking which does not have

your house key with it. An unscrupulous parking attendant can have a house key made within just a few minutes, and with your car registration at hand, it is a simple matter to put the two together.

- 4** Moving into a new home or apartment? Change the locks as soon as you are moved in. A locksmith can do this inexpensively or if you are handy with tools, you can do this yourself in a matter of minutes.
- 5** Know who has every key to your home. Don't give keys to maintenance or delivery people.

security can be obtained from cremone or slide bolts going into the header and threshold, with at least a 1" throw. If hinges are on the exterior of the door they should have non-removable pin type hinges.

Hollow Core Doors

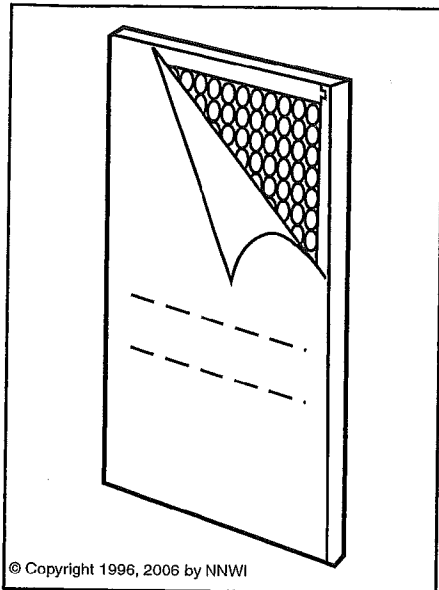

This door is typically made of two veneer wood panels covering an interior of cardboard or other material acting as a spacer. The outer frame and a block for mounting the lock are virtually the only solid components of the door. This door can be distinguished from a solid core door by its lack of weight and dull sound when knocked on. These are only recommended for interior use, such as for closets, bathrooms and other rooms such as bedrooms that need to be latched, but not seriously secured against intruders. This type of door can be easily kicked in, leaving a hole through which any locking device is accessible. If you can not replace this type of door with a solid core door, this hollow core door can be reinforced with an additional layer of 1" exterior plywood bolted to the door.

Doors with glass, or glass within 36" of the door

Install a non-breakable glass replacement such as Lexan, or security film such as Armor-Coat.

Sliding Glass Doors

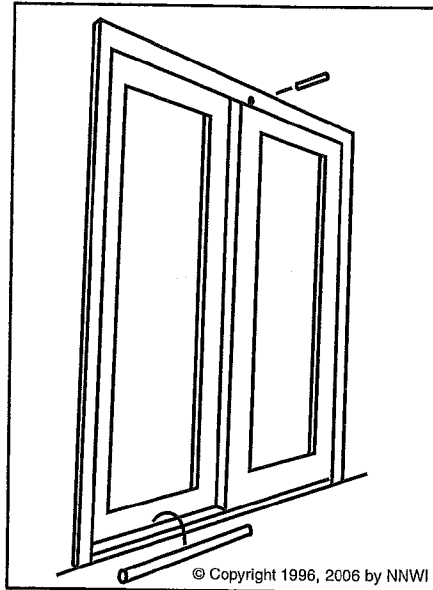

These doors move horizontally on tracks. The moving door typically moves on the inside track, but not necessarily so. Locks are usually inadequate. If the door slides on the **inside** track, a dowel placed in the track will prevent the door from being slid open. (See illustration above.)

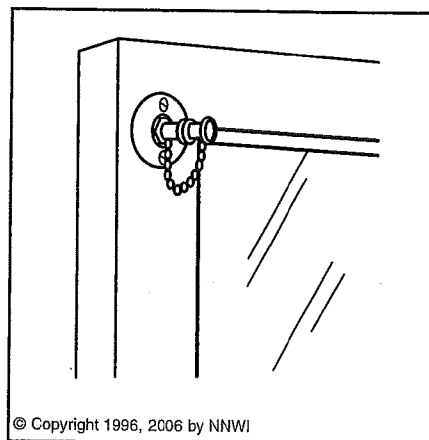

Another option would be to drill and pin through the overlapping frames and installation of a removable pin. (See illustration above.)

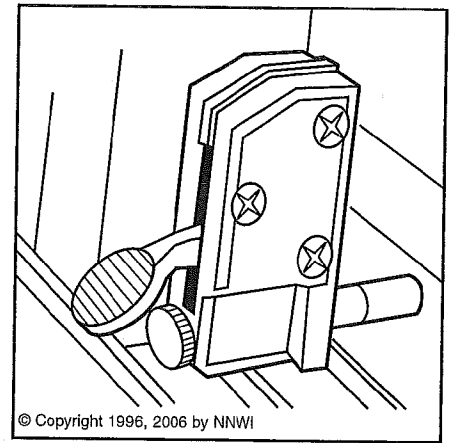

If the door slides on the **outside** track, you are best installing a keyed slide bolt. (See illustration above.)

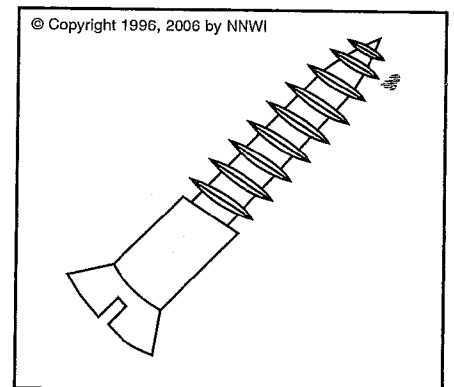

To prevent the door from being lifted out of its frame, a common move for burglars, install screws in the upper track so the screw heads protrude just enough to clear the sliding door when it is closed. (See illustrations above and on page 16.)

Door Frames

Door frames either pre-hung, or framed in. Since a lock is intended to keep the door secured to the frame, a strong frame is extremely important. Since most homes built since World War II (1946 and later) have a pre-hung door frame, you might want to do the following:

See if the door frame is mounted securely. Remove the interior door molding and see how much gap, if any, exists between

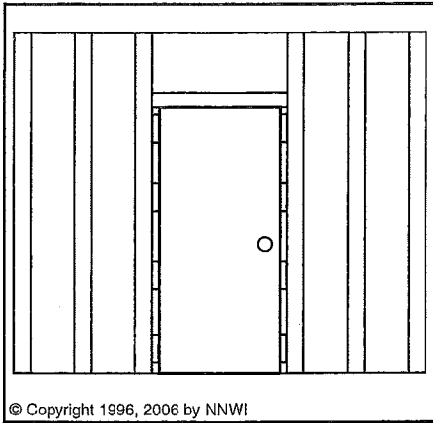

© Copyright 1996, 2006 by NNWI

the door frame and the building studs. Shims are generally used to square and plumb the door and often a gap exists between them. Add shims, if possible, between the door frame and the studs to give it extra strength, especially around the area of the strike plate and its lock. Use high security strike plates on this type of door construction. They should be at least 4" long, with 4 screw holes. The screws should be long enough to reach the studs. Some homes, older and custom homes, will have frames that were built as part of the wall.

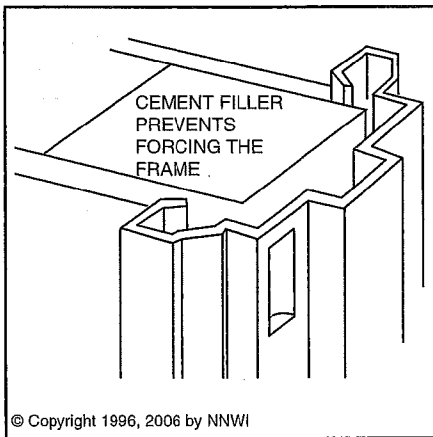

© Copyright 1996, 2006 by NNWI

This type of construction is extremely strong and is difficult to kick in when a 1" deadbolt is used. Hopefully no gap exists between the door frame and the building studs.

Door Hinges on Exterior Doors

Doors with exposed hinges and exterior security door hinges

should have pins welded in place, drilled and pinned, or replace the hinges with non-removable-pin type

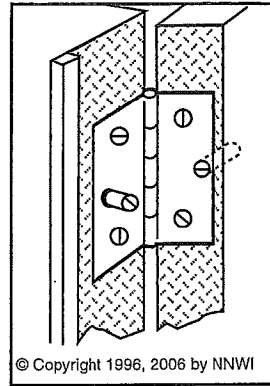

© Copyright 1996, 2006 by NNWI

hinges. Interior hinges should have non-removable hinge pins so as not to allow an easy exit for the intruder. This is only applicable to commercial prop-

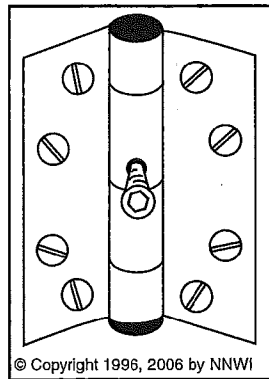

© Copyright 1996, 2006 by NNWI

erty, since residences should always be openable from the inside, as a fire safety measure.

Mail Slots

Mail slots should be no larger than 2" wide, not within 30" of a door and always angled downward to prevent a burglar from being able to reach through the slot to open the door.

Garage Doors

Garage doors should be kept closed at all times whether you are in the home or away. They should only be open when you are working in and about the garage, or moving a vehicle in or out. If a burglar gets into your garage, and your garage is attached to your house, he has plenty of time to gain entry into your home through the connecting doors because he will be out of sight of your neighbors. Add to this predicament a number of tools you probably have in the

garage to assist in a break in. Even passers-by walking, jogging or bicycling by your open, unattended, garage are faced with temptation.

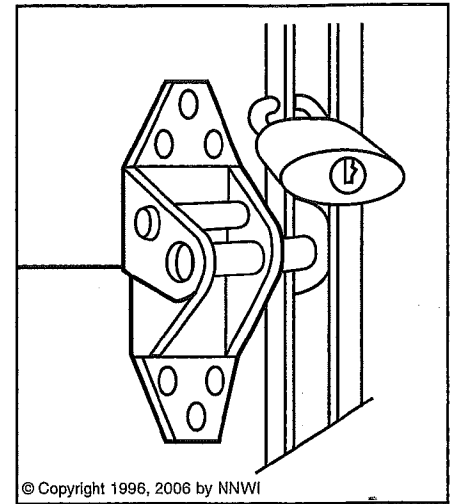

© Copyright 1996, 2006 by NNWI

To secure your overhead garage door, drill a hole through the track above a roller, or through the end of the deadbolt latch that protrudes through the track. Insert a heavy bolt or case-hardened padlock. Thin door panels should be reinforced. Windows should be covered to prevent someone from looking in to determine if anyone is home or if any property inside is worth stealing.

Garage doors that swing out horizontally can be secured by installing surface bolts at the top and bottom of one door and a hasp and padlock on the outside or inside of the doors.

If you have, or plan to install, an electric garage door opener, it should be of the electronic digital code variety, so that the door will not accidentally open by random sounds. Check the door periodically to make sure that it is engaged and can not be lifted from the bottom. If you will be away for an extended period of time, disconnect the garage door opener.

WINDOWS

Security for Double-Hung or Sash Windows:

The two significant weaknesses in this type of window concern the center closing latch. The glass can be broken and the latch opened. The latch can be pried or forced off the window with a pry tool from the outside. This type window can be secured by:

Drilling and Pinning:

With the window in a closed

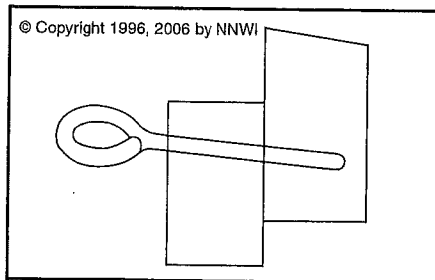
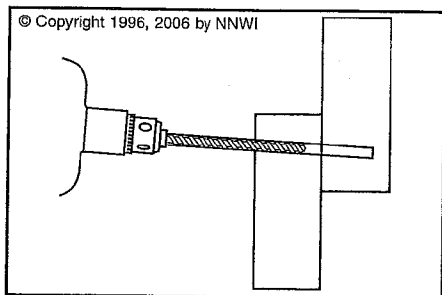

position, from inside the house, drill a hole in the two overlapping corners of the inside sashes. These two holes should be drilled on a downward slant and the drill hole should continue into the second sash,

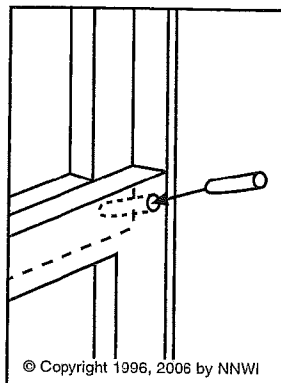

without passing all the way through to the outside. Insert double-headed nails into these holes. This effectively secures the window against intruders, while allowing easy exit in case of fire by pulling up the nails. A second pair of holes can be drilled above the first holes to pin the window slightly open to provide ventilation.

Vertical Rods:

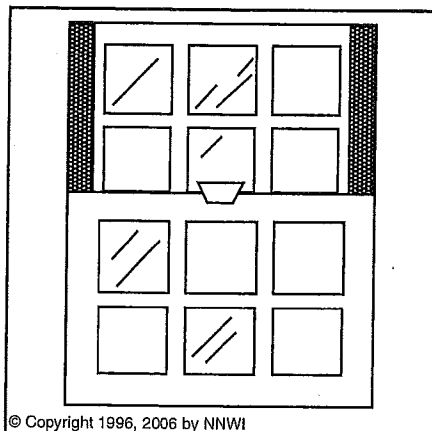

With the window in a closed position, place dowels, rods or boards in the inside vertical track. These should be placed on each side of the window interior to make it difficult for the intruder to pry the window open. The dowel, rod or board should be sufficiently strong to prevent breaking by being squeezed vertically when an intruder tries to lift the window.

Diagonal Rod:

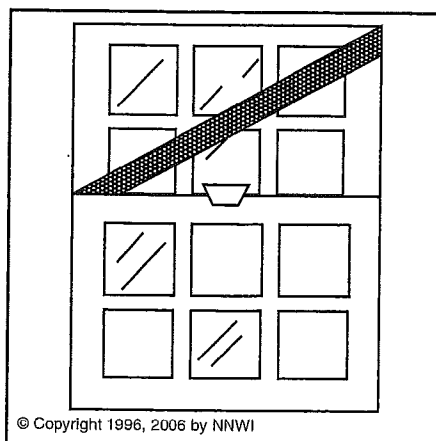

Place the dowel, rod or board diagonally across the inside of the window.

Key Latch:

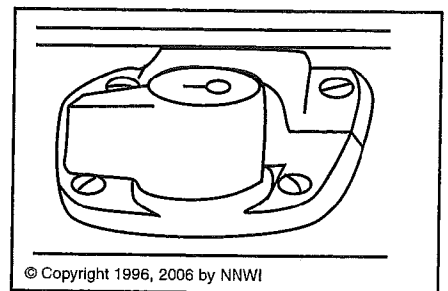

Consider replacing the unkeyed latch with a keyed one. It should be secured with at least 3/4" screws to prevent it from being easily pried off. These windows should only be locked when the house is vacant. Windows need to be kept accessible in case of fire when you are at home.

Security for Sliding Glass Doors and Windows:

Sliding glass doors and windows are generally made of aluminum and can easily be forced open with a pry bar or screwdriver, then removed from the outside by lifting the door or window above the metal lip of the track and then pulling out.

Drilling and Pinning:

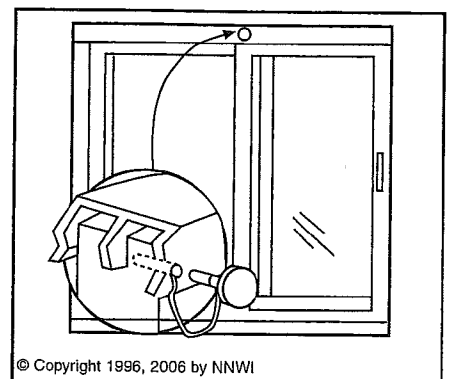

With the door or window closed, drill a hole through the center of the inside frame and part way

through the outside frame. Then place a pin or nail through the hole. This will prevent the door from being forced open or lifted from its track.

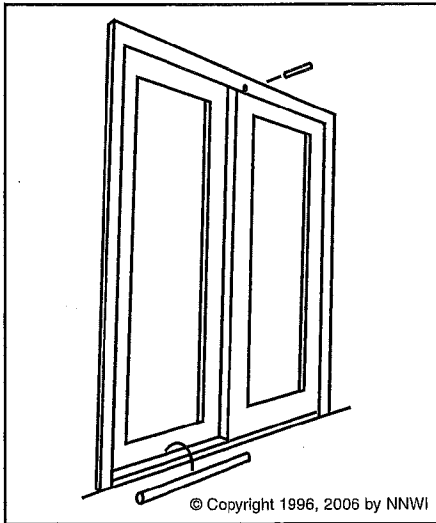

Board or Rod:

With the window or door closed, place a dowel, rod or board in the inside track. This will only help if the moving door is installed on the inside track while the stationary door is on the outside. Charlie bars, aluminum rods that are designed for this purpose are available at most hardware stores. Make sure the rod fits snugly.

Adjustable Screws

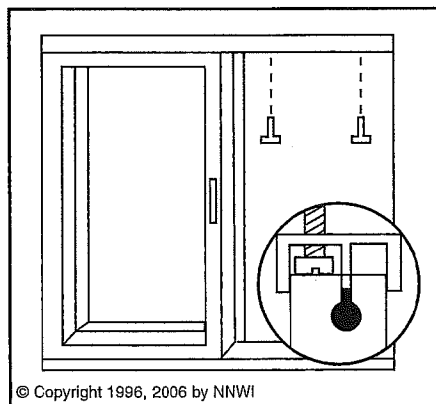

in the Upper Track:

With the door or window open, drill holes and install several screws in the upper track. Adjust

them so that the window or door just barely clears the screw-head. This method is designed only to prohibit the door or window from being lifted from its track.

Security for Basement, Garage and Door

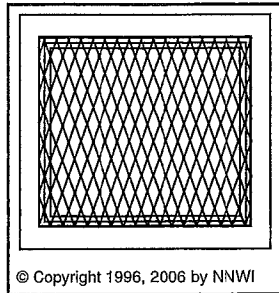

Windows:

Don't seal off windows in such a manner that you create a fire trap in your home. One window per basement room needs to be open-

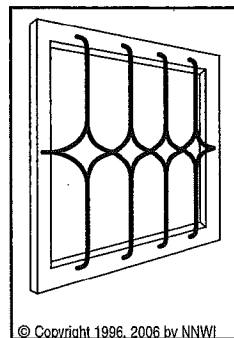

able as an emergency fire exit. Basement windows can be covered with 12 or 19 gauge expanded metal or ornamental grill work.

Wherever possible, install so that windows can still be opened for emergency exit

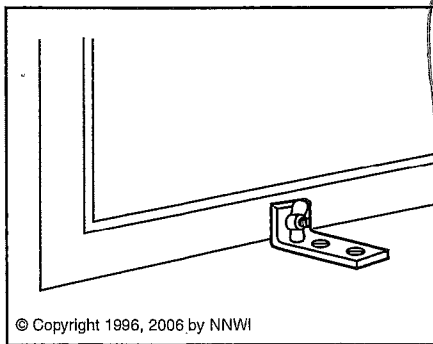

purposes.

A length of metal pipe installed on the inside of the house can secure a basement window.

Casement Windows:

Remove crank and/or add an angle iron, carriage bolt and

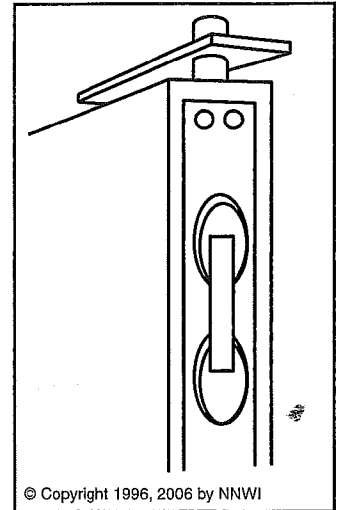

wing nut.

French Windows:

Secure with self-mounted flush bolts at the top and bottom of each window.

Hinged Windows:

Secure with a flush bolt or surface bolt.

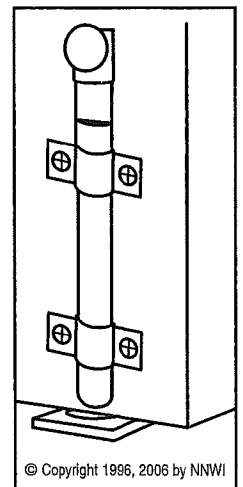

Louvered Windows:

