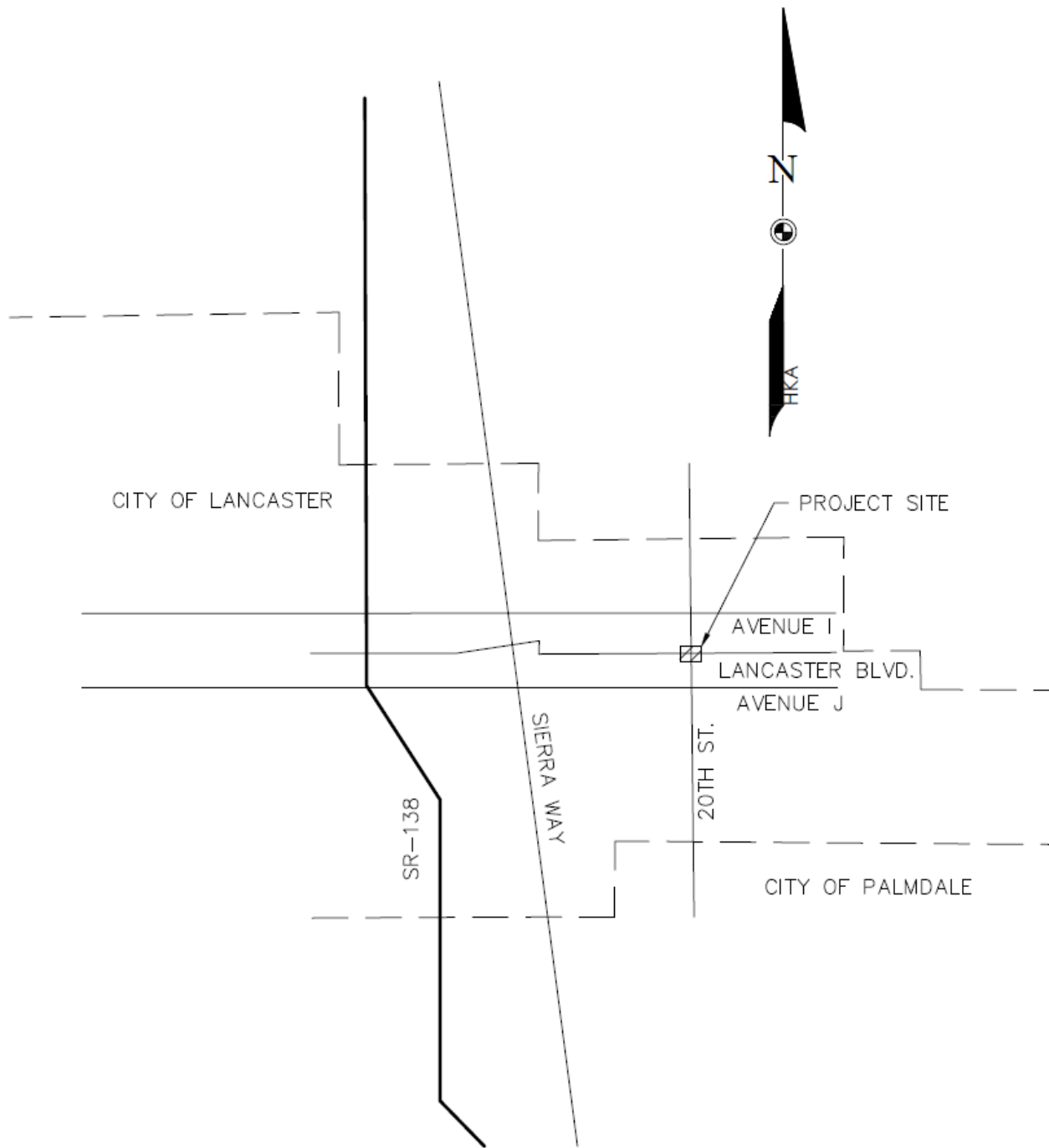


Figure 1-A



**VICINITY MAP**

NOT TO SCALE

Figure 2-A

## LINE LEGEND

---

————— W —————	EXISTING WATER LINE
————— S —————	EXISTING SEWER LINE
————— SD —————	EXISTING STORM DRAIN LINE
————— G —————	EXISTING GAS LINE
————— T —————	EXISTING TELEPHONE LINE
————— SD —————	PROPOSE STORM DRAIN LINE
————— — — —————	CENTERLINE
————— — — —————	EXISTING R/W
————— — — —————	PROPOSED R/W
————— — — —————	EXISTING CONDUIT
————— — — —————	PROPOSED CONDUIT

Figure 2-B

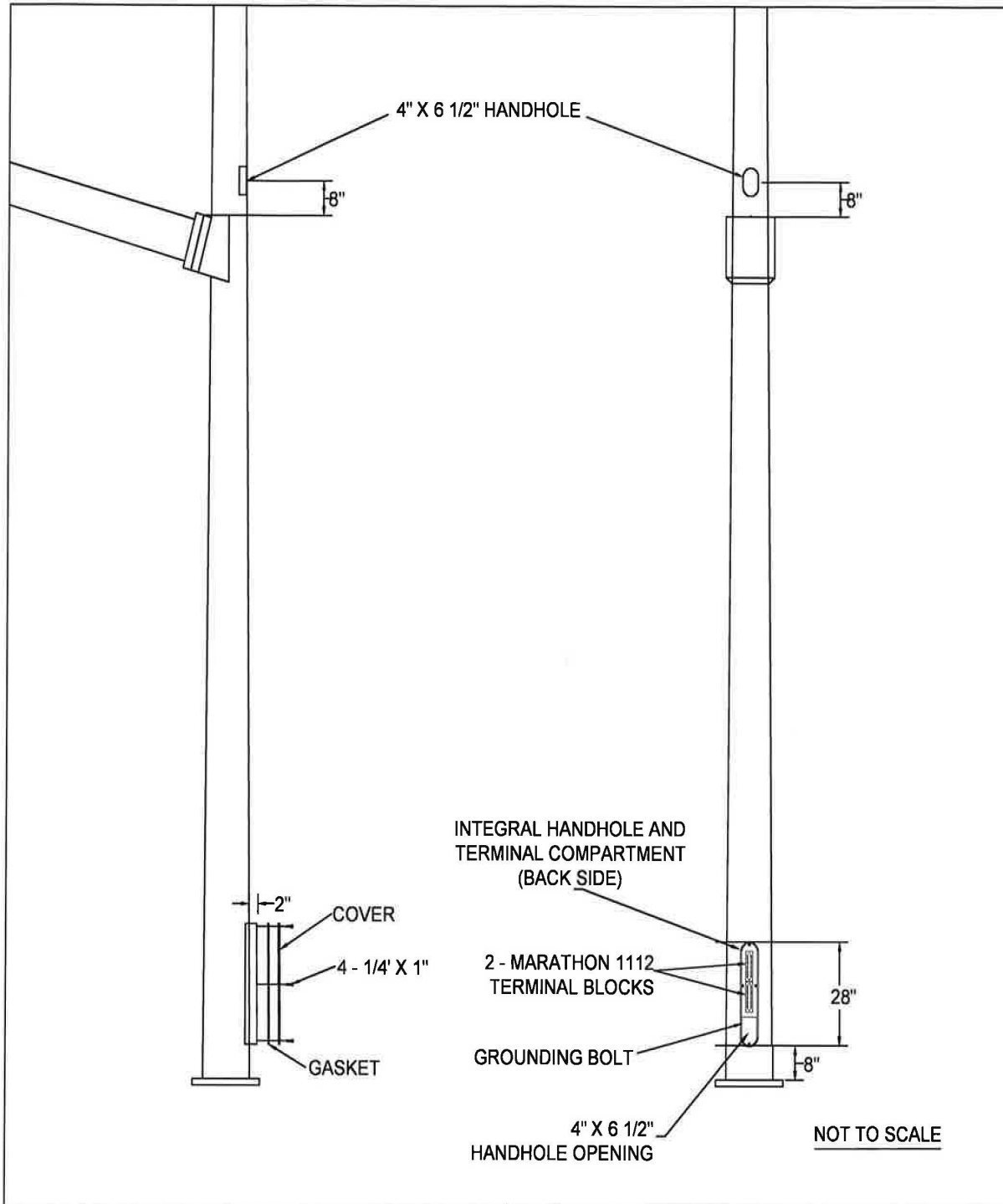
## ABBREVIATION

---

EX	—	EXISTING
PROP	—	PROPOSED
R/W	—	RIGHT OF WAY
PB	—	PULLBOX
EP	—	EDGE OF PAVEMENT
ST.	—	STREET
BLVD.	—	BOULEVARD
€	—	CENTER LINE
TYP	—	TYPICAL
SNS	—	STREET NAME SIGN
&	—	AND

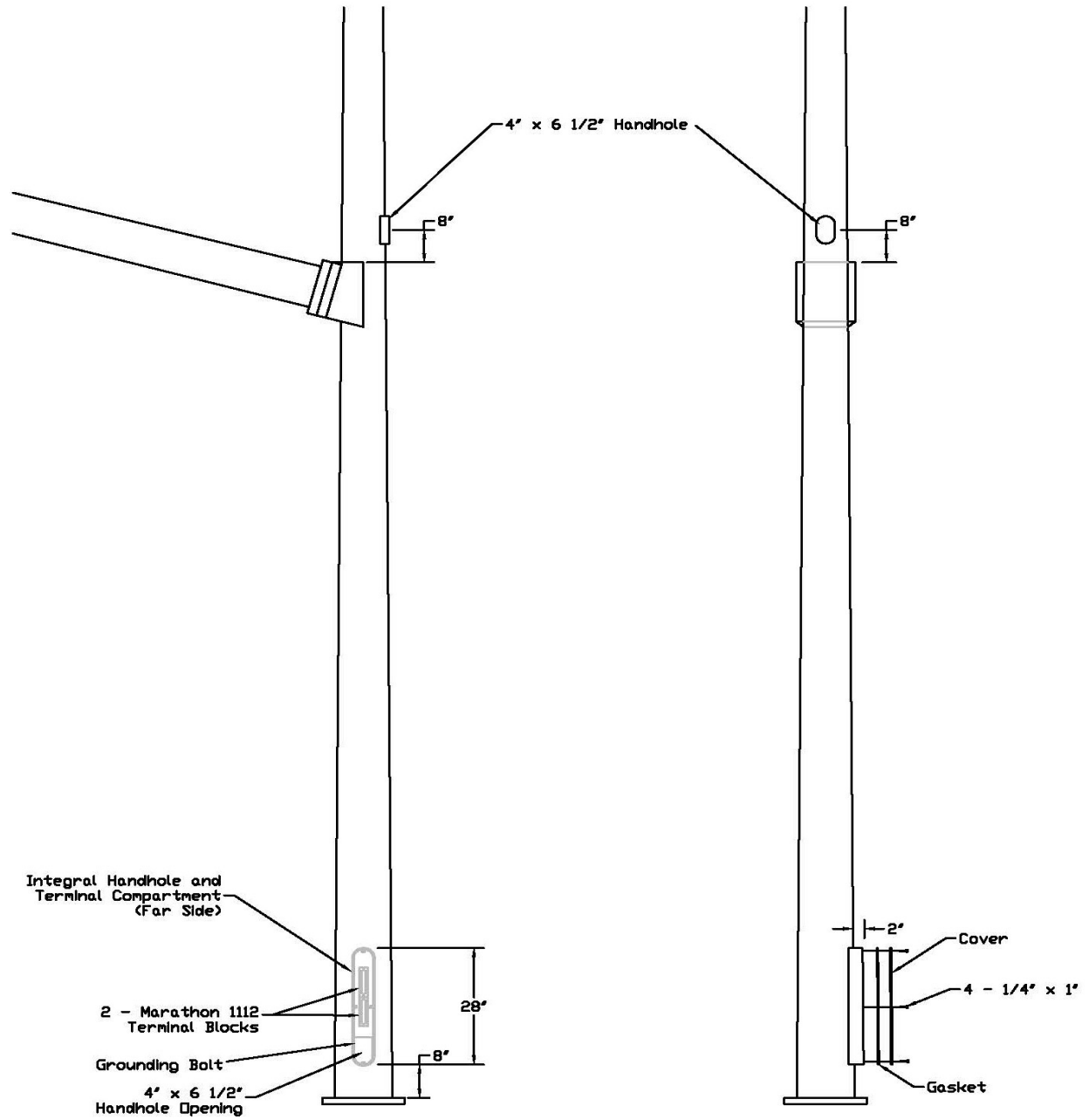
---

Figure 3-A



90 DEGREE TERMINAL BLOCK TO BE USED IF OBSTRUCTIONS ARE PRESENT

Figure 3-A1



NOT TO SCALE

TRAFFIC SIGNAL STANDARD DETAIL

Figure 3-B

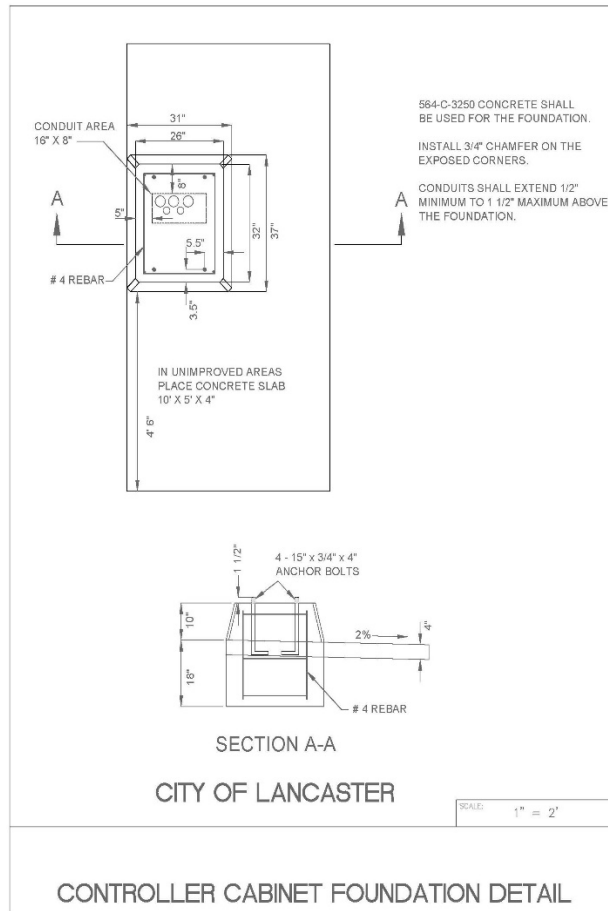


Figure 4-A

**GENERAL NOTES:**

1. ALL TRAFFIC SIGNAL WORK AND HIGHWAY SAFETY LIGHTING SYSTEMS MATERIALS, AND EQUIPMENT PROPOSED IN THE PLAN SHALL CONFORM TO THE CURRENT EDITION OF CALTRANS STANDARD SPECIFICATIONS, STANDARD PLANS, AND THE LATEST EDITION OF THE CALIFORNIA MUTCD AND ALL REVISIONS AND DOCUMENTS REFERENCED THEREBY. SEE CITY OF LANCASTER SPECIAL PROVISIONS.
2. ALL NEW TRAFFIC SIGNAL POLES SHALL USE THE 2010 CAL TRANS STANDARD SPECIFICATIONS AND STANDARD PLANS.
3. IT SHALL BE THE CONTRACTORS RESPONSIBILITY TO DETERMINE THE LOCATION AND DEPTH OF ALL UNDERGROUND UTILITIES WITHIN THE CONSTRUCTION LIMITS.
4. THE CONTRACTOR SHALL BE RESPONSIBLE FOR THE COORDINATION OF ALL WORK ON THIS PROJECT.
5. CONDUIT SHALL BE 4" FOR ALL CROSSINGS.
6. CONDUITS GOING INTO AND OUT OF THE SIGNAL CABINET AND POWER PEDESTAL SHALL BE RIGID METAL.
7. CONDUIT BETWEEN STANDARD AND ADJACENT PULLBOX SHALL BE 3" RIGID METAL FOR SIGNAL MAST ARM POLE, 2.5 FOR TYPE 15-TS POLE, AND 2" FOR TYPE 1A POLE, UNLESS SHOWN OTHERWISE.
8. WHERE NEW CONDUCTOR CABLES ARE SPECIFIED, THE EXISTING CABLES SHALL BE REMOVED.
9. FACE OF POLES TO BE 6' BEHIND CURB UNLESS OTHERWISE NOTED. LOCATION FROM BCR AND ECR AS SHOWN IN POLE SCHEDULE. LOCATION OF POLE TO BE APPROVED BY THE CITY INSPECTOR PRIOR TO ORDERING POLES OR CONSTRUCTION OF FOUNDATION.
10. SALVAGED POLES, EQUIPMENT, SIGNS, ECT, SHALL BE RETURNED COMPLETE WITH ALL ASSOCIATED HARDWARE TO THE CITY YARD PER CITY'S DISCRETION. UNWANTED ITEMS SHALL BE DISPOSED OF BY THE CONTRACTOR.
11. ALL PULL BOXES SHALL BE NO.6 EXCEPT WHERE NOTED ON THE PLAN. PULL BOXES SHALL NOT BE PLACED IN CURB RAMPS, DRIVEWAYS, OR OTHER LOCATIONS THAT MAY BE SUBJECT TO VEHICLE TRAFFIC UNLESS APPROVED BY THE ENGINEER.
12. ALL SIGNAL HEADS SHALL BE 12" WITH HIGH VISIBILITY LOUVERED BACKPLATES AND TUNNEL VISORS.
13. ALL PEDESTRIAN SIGNALS SHALL BE TYPE A, COUNTDOWN TYPE.
14. ALL VEHICLE AND PEDESTRIAN INDICATORS SHALL BE L.E.D.
15. ALL SIGN NUMBERS REFER TO THE CURRENT VERSION OF THE CALIFORNIA MUTCD.
16. WHEN SPLICING FIBER OPTIC CABLE, THE FIBER OPTIC CABLE BEING SPLICED SHALL BE PULLED BACK FROM THE NEAREST INTERSECTION, SPLICED, AND A NEW FIBER OPTIC CABLE SHALL BE PULLED BACK TO THE INTERSECTION.
17. THE EXISTANCE AND LOCATION OF ANY UNDERGROUND UTILITY PIPES, CONDUITS, OR STRUCTURES SHOWN ON THESE PLANS WAS OBTAINED BY A SEARCH OF THE AVAILABLE RECORDS. TO THE BEST OF OUR KNOWLEDGE, THERE ARE NO EXISTING UTILITIES EXCEPT AS

SHOWN ON THESE PLANS. THE CONTRACTOR IS REQUIRED TO TAKE DUE PRECAUTIONARY MEASURES TO PROTECT EXISTING UTILITIES. THE CONTRACTOR FURTHER ASSUMES ALL LIABILITY AND RESPONSIBILITY FOR THE UTILITY PIPES, CONDUITS, OR STRUCTURES SHOWN OR NOT SHOWN ON THESE DRAWINGS. THE CONTRACTOR SHALL POTHOLE ALL EXISTING UTILITIES TO VERIFY THE LOCATION, AND ANY DISCREPANCY ON THE PLANS SHALL BE BROUGHT TO THE ATTENTION OF THE ENGINEER.

18. PRIOR TO EXCAVATION, THE CONTRACTOR SHALL CALL AND OBTAIN UNDERGROUND SERVICE ALERT ID NUMBER BY CALLING 1-800-422-4133.
19. THESE PLANS ARE HERBY MADE PART OF THE SPECIFICATIONS.
20. REQUEST FOR INSPECTION SERVICE BY THE CITY OF LANCASTER DEPARTMENT OF PUBLIC WORKS SHALL BE MADE BY THE CONTRACTOR AT LEAST TWENTY-FOUR (24) HOURS BEFORE THE SERVICES ARE REQUIRED. TO REQUEST INSPECTION SERVICES CALL (661) 945-6873.
21. ACCESS TO ALL DRIVEWAYS AND BUSINESSES SHALL BE PROVIDED AND MAINTAINED DURING THE ENTIRE PERIOD OF CONSTRUCTION.
22. NO WORK IN CONNECTION HERewith SHALL BE CONDUCTED BETWEEN THE HOURS OF 5:00 PM AND 7:00 AM OF ANY DAY, NOR ON SATURDAYS, SUNDAYS, OR HOLIDAYS WITHOUT PRIOR WRITTEN APPROVAL OF THE LANCASTER CITY ENGINEER
23. HOLES LEFT IN SHAFT OF AN EXISTING STANDARD DUE TO THE REMOVAL OF EQUIPMENT MUST BE SEALED WITH A METHOD APPROVED BY THE ENGINEER.
24. ALL MATERIAL SHALL BE FURNISHED AND INSTALLED BY THE CONTRACTOR.
25. ANY ACTIVE LOOPS DAMAGED DURING CONSTRUCTION SHALL BE REPLACED BY THE CONTRACTOR AT THE CONTRACTOR'S EXPENSE.
26. A SCE APPROVED HIGH VOLTAGE CONTRACTOR SHALL BE USED WHEN WORKING IN CLOSE PROXIMITY TO HIGH VOLTAGE POWER LINES
27. CONTRACTOR'S RESPONSIBILITY STATEMENT: CONTRACTOR AGREES THAT THEY SHALL ASSUME SOLE AND COMPLETE RESPONSIBILITY FOR THE JOB SITE CONDITION DURING THE COURSE OF CONSTRUCTION OF THIS PROJECT, INCLUDING SAFETY OF ALL PERSONS AND PROPERTY. THIS REQUIREMENT SHALL APPLY CONTINUOUSLY AND NOT BE LIMITED TO NORMAL WORKING HOURS. THE CONTRACTOR ALSO AGREES TO DEFEND, INDEMNIFY, AND HOLD THE CITY OF LANCASTER HARMLESS FROM ANY AND ALL LIABILITY, REAL OR ALLEGED IN CONNECTION WITH THE PERFORMANCE OF WORK ON THIS PROJECT, EXCEPT FROM LIABILITY ARISING FROM THE SOLE NEGLIGENCE OF THE OWNER OR THE ENGINEER.
28. EXISTING HAZARDOUS MATERIALS: THE EXISTENCE AND LOCATION OF HAZARDOUS MATERIALS HAS NOT BEEN REVIEWED BY THE ENGINEER OR SHOWN ON THESE PLANS. THE CONTRACTOR IS REQUIRED TO TAKE DUE PRECAUTIONARY MEASURES. INCLUDING AN INVESTIGATION IF NEEDED, TO PROTECT ANY EXISTING HAZARDOUS MATERIALS IN PLACE OR TO PROVIDE SUITABLE DISPOSAL, IT SHALL BE THE CONTRACTORS RESPONSIBILITY TO NOTIFY THE OWNER(S) OF KNOWN HAZARDOUS MATERIALS BEFORE STARTING CONSTRUCTION. IT SHALL BE THE CONTRACTOR'S RESPONSIBILITY TO PROTECT THE SITE AND PERSONNEL FROM CONTAMINATION OF KNOWN HAZARDOUS MATERIALS DURING CONSTRUCTION.

Figure 5-A

Part T

Specifications (General Information) should be on all plans

Standards, steel pedestals, and posts (Signal poles and mast arms)

Mast arm mounted signs (Street name or S.G. signs)

Standard foundation detail (Cabinet foundation)

Conduit (Type and size of conduits to use)

Pull boxes (Type and size to use)

Conductors and wiring (Type, size, and termination instructions)

Service (Power pedestal / Myers can)

332 Controller cabinet and model 2070 ATC controller assemblies (Specs on Signal cabinet, controller, CMU, and BBS system)

Bonding and Grounding (Ground for signal cabinet)

Vehicle signal faces (Specs for Traffic signal heads, backplates, indications, and visors)

Pedestrian signals and push buttons (Specs for Ped heads, Ped plates, housings, and indications)

Vehicle detection (Specs for video and loop detectors)

HD IP CCTV camera system (Type of camera and mounting instructions)

Luminaires (Specs for safety lighting)

Fiber optic communications (Specs for fiber optic cable, equipment, splicing, and testing)

IP Networking equipment (Specs for ethernet edge switch)

Wireless Ethernet broadband system (Specs for wireless communications and antenna)

Flashing pedestrian crosswalks

Signal turn on (Instructions for turning on the signal)



TRAFFIC ENGINEERING

TRAFFIC SIGNAL PLAN INDEX CIP

Maintaining existing and temporary electrical systems (Instructions for signal shut downs and temporary poles)

Removing electrical equipment (Instructions on salvaged and unwanted equipment)

Payment (Lump sum or unit bid pricing)

Figure 6-A

**Signature Block:**

Placement is to remain in the upper right hand corner of the plan sheet, except for Sewer Plan.

**(1) For Grading, Street Improvement, Street Light, Storm Drain, LMD, Recycled Water, Traffic Signal, Traffic Signing and Striping, and Traffic Control plans:**

<i>All Sheets</i>	CHECKED BY:	_____	_____
			DATE
<i>Title Sheet Only</i>	REVIEWED BY:	_____	_____
			DATE
	APPROVED BY:	_____	_____
			DATE

**Title Block:**

Placement is to remain in the bottom right corner of the plan

<i>All Sheets</i>	CITY OF LANCASTER TRAFFIC SIGNAL PLAN		
	<b>ARTERIAL STREET AT MINOR STREET</b>		
	PROJECT #	SHEET X OF X	SCALE : 1" = 20'

Figure 6-B

**B. Revision Block:**

(1) For Grading, Street Improvement, Street Light, Storm Drain, LMD, Recycled Water plans, Traffic Signal, Traffic Signing and Striping, and Traffic Control plans (to appear on all sheets):

REV #	RECORD RCE		REVISION BLOCK REVISION DESCRIPTION	CITY	
	APPR	DATE		APPR	DATE
△					

**C. As-Built Block:**

(1) For Street Improvement, Street Light, Storm Drain, LMD, Sewer, Recycled Water, Traffic Signal, and Traffic Signing and Striping plans (to appear on all sheets):

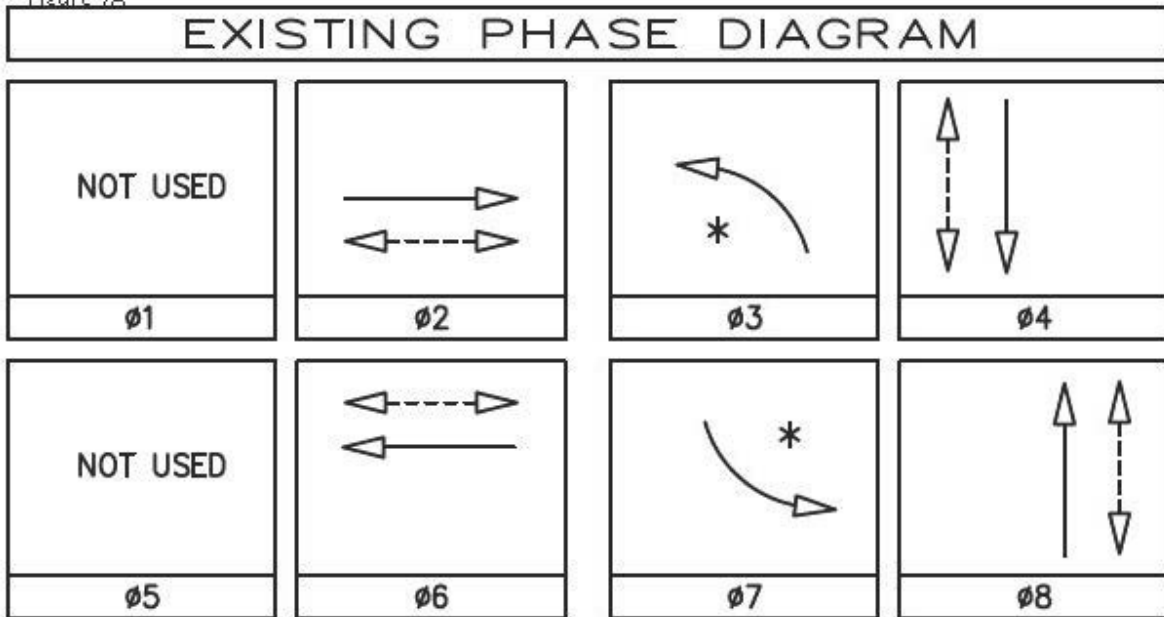
<p><b>AS-BUILTS</b></p> <p>BASED UPON INFORMATION SUPPLIED BY THE CITY INSPECTOR AND CONTRACTOR (NOT) FIELD VERIFIED</p>				
<table style="width: 100%; border: none;"> <tr> <td style="border: none; width: 33%;">ENGINEER: (NAME)</td> <td style="border: none; width: 33%;">RCE (NUMBER)</td> <td style="border: none; width: 33%;">DATE</td> </tr> </table>	ENGINEER: (NAME)	RCE (NUMBER)	DATE	
ENGINEER: (NAME)	RCE (NUMBER)	DATE		
<p>APPROVED BY:</p>  <p style="text-align: right;">DATE _____</p>				

**D. Engineer's stamp:**

(1) To be placed to the left of revision and as-built blocks (to appear on all sheets):

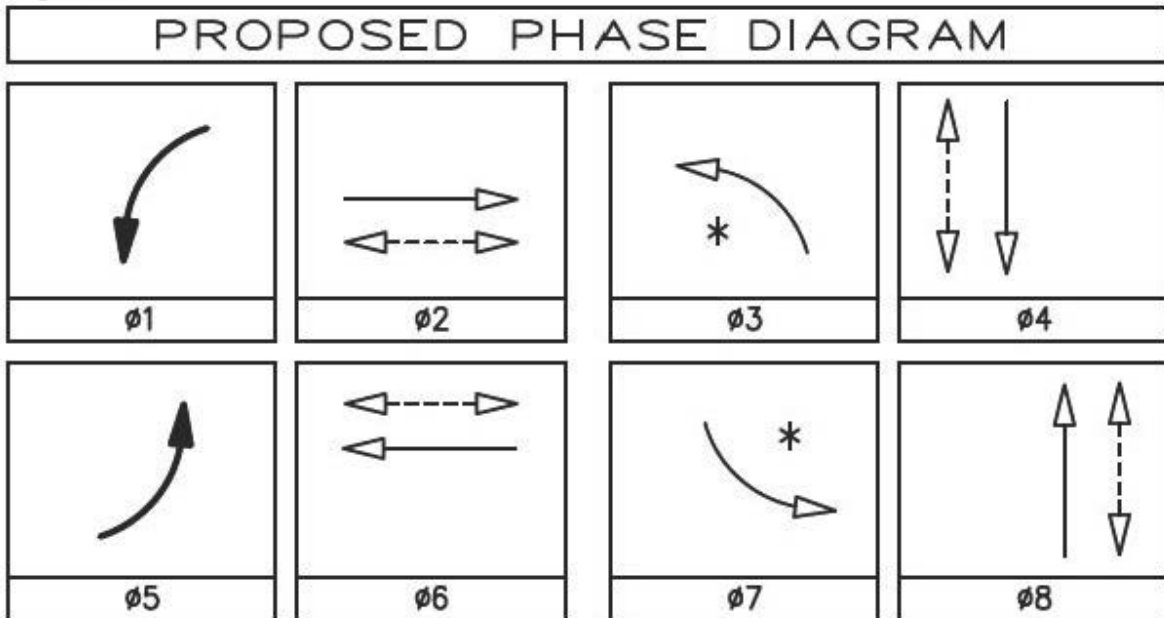


Figure 7A



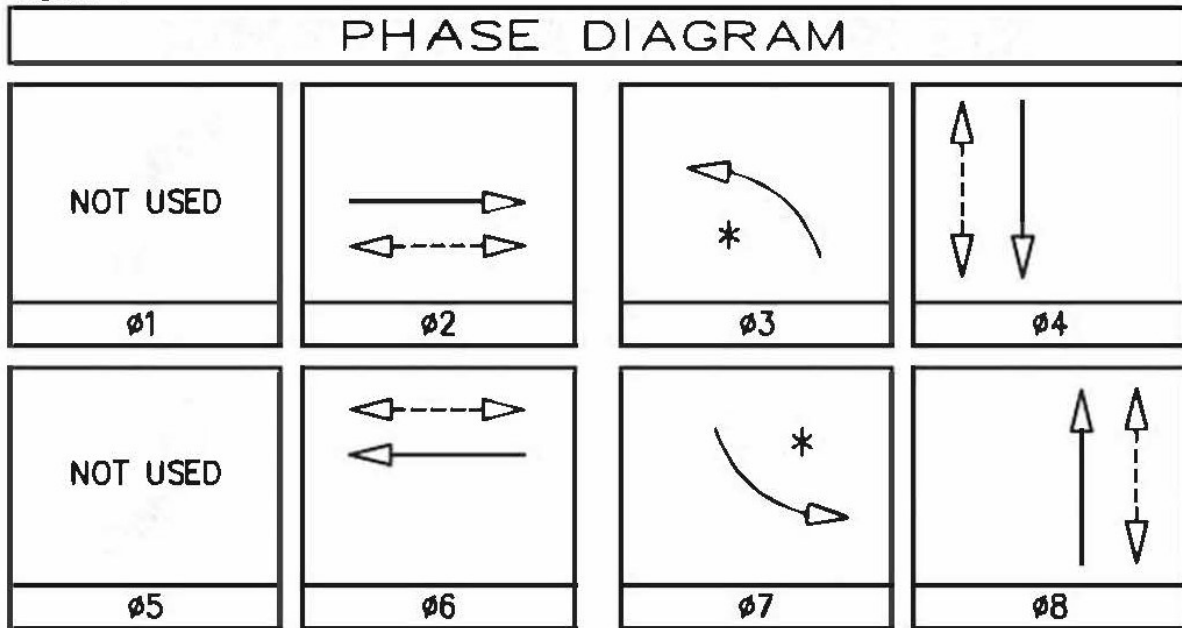
\* PROTECTIVE/PERMISSIVE LEFT TURN

Figure 7 B



\* PROTECTIVE/PERMISSIVE LEFT TURN

Figure 7 C



\* PROTECTIVE/PERMISSIVE LEFT TURN

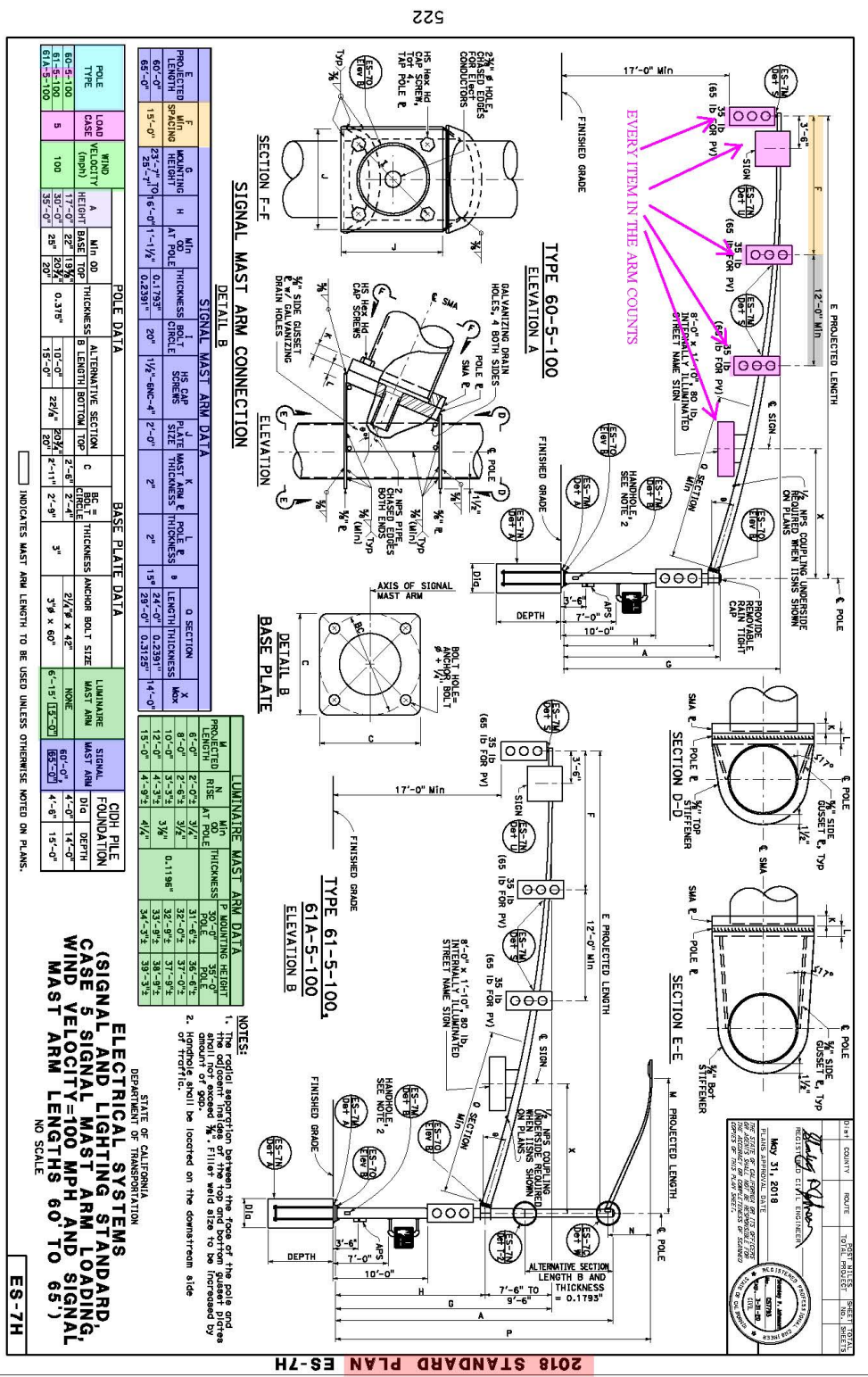
Figure 13A

CALTRANS STANDARD		STANDARD		HEIG-TH		SIG.M.A.		LUM.M.A.		LUMINAIRE		R.S.V.S.		SIGNAL		VEHICLE		PHASE		PUSH		POLE		REMARKS	
No.	STANDARD	TYPE	HEIGHT	SIG.M.A.	LUM.M.A.	LUMINAIRE	LEGEND	VEHICLE	PHASE	PUSH	POLE	REMARKS													
A	1992	26-4-80	30'	45'(N) 35'(RS) ▲	'5'	150W(N)	27th Street West (R)	MAS(N) MAS(R)	SV-1-T TV-1-T	SP-1-T SP-1-T	8 2	← ←	EXISTING A=3' 6'	1 2 3 4											
B	1992	1-A	'0'	-	-	-	-	-	TV-1-T	SP-1-T	2	←	EXISTING	1 2											
C	1992	17-2-80	30'	20'	'5'	150W(N)	Avenue J	VAS	SV-1-T	SP-1-T	4	→	EXISTING	1 2											
D	1992	15-TS	30'	-	'5'	150W(N)	-	-	SV-1-T	SP-1-T	2	→	B=5' 6'	1 2											
E	1992	26-4-80	30'	45'(N) 35'(RS) ▲	'5'	150W(N)	27th Street West (R)	MAS(N) MAS(R)	SV-1-T	SP-1-T	4	←	EXISTING	1 2 3 4											
F	1992	1-A	'0'	-	-	-	-	-	TV-1-T	SP-1-T	6	→	C=4' 6'	1											
G	1992	17-2-80	30'	20'	'5'	150W(N)	Avenue J	VAS	SV-1-T	SP-1-T	6	←	EXISTING	1 2											
H	1992	15-TS	30'	-	'5'	150W(N)	-	-	SV-1-T	SP-1-T	8	→	D=2' 6'	1 2											

■ ALL EQUIPMENT IS EXISTING UNLESS OTHERWISE NOTED: (N)=NEW, (R)=RELOCATE  
 ✱ INS-TALL/REPLACE HIGHWAY SAFETY LIGHT WITH LED EQUIVALENT.  
 ▲ USE CALTRANS SIGN PLAN 1992 STANDARD FOR AND SPECS.

- 13
- 14
- 15
- 16
- 17
- 18
- 19
- 20
- 21
- 22 +
- 23
- 24 +
- 25
- 26
- 27
- 28 +
- 29
- 30
- 31

- 14
- 15
- 16
- 17
- 18
- 19
- 19A
- 19B
- 20



Return to Table of Contents

Figure 24 A

CALTRANS signal head standard identifying system

**MAS**- 3-section signal head on mast arm

**MAT** tenon on top 3-section signal head on mast arm

**MAS 4** (A, B, or C) 4-section signal head on mast arm check CALTRANS specs for configuration A, B, or C  
(Configuration should be shown on plans)

**MAS 5** (A, B, or C) 5-section signal head on mast arm check CALTRANS specs for configuration A, B, or C  
(Configuration should be shown on plans)

**SV or TV-1-T** (A, B, C, or D) **SV** = Side mount vehicle head =**10'** **signal head** mounted on the pole not the mast arm (3 section standard, specify if 4 or 5 section)-**1** =number of signal faces-**T** = terminal compartment check CALTRANS specs for configuration A, B, C, or D if more than one signal face is used  
(Configuration should be shown on plans)

**TV=Top mount vehicle head (used for 1-A poles)**



Figure 24 B

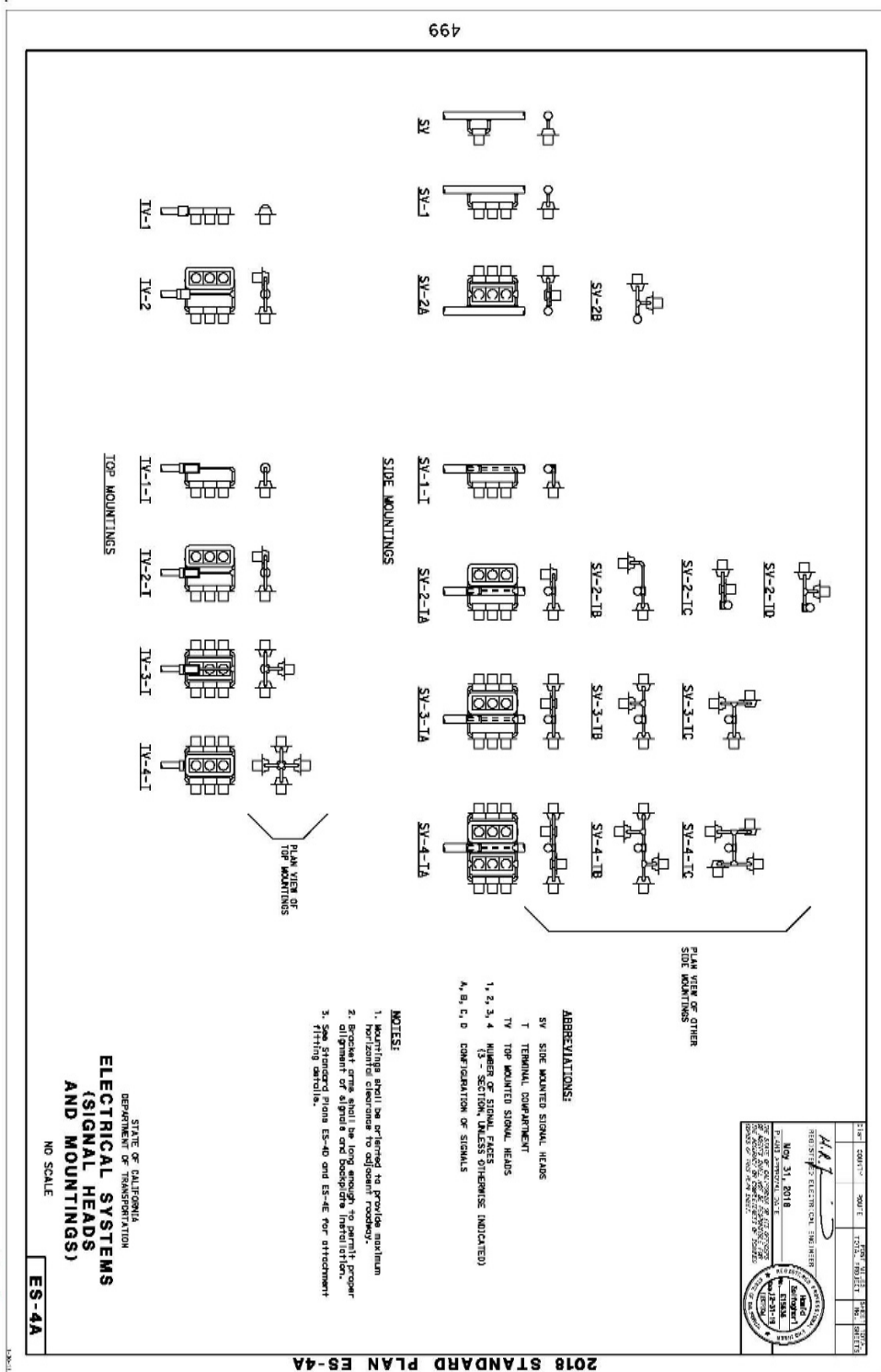
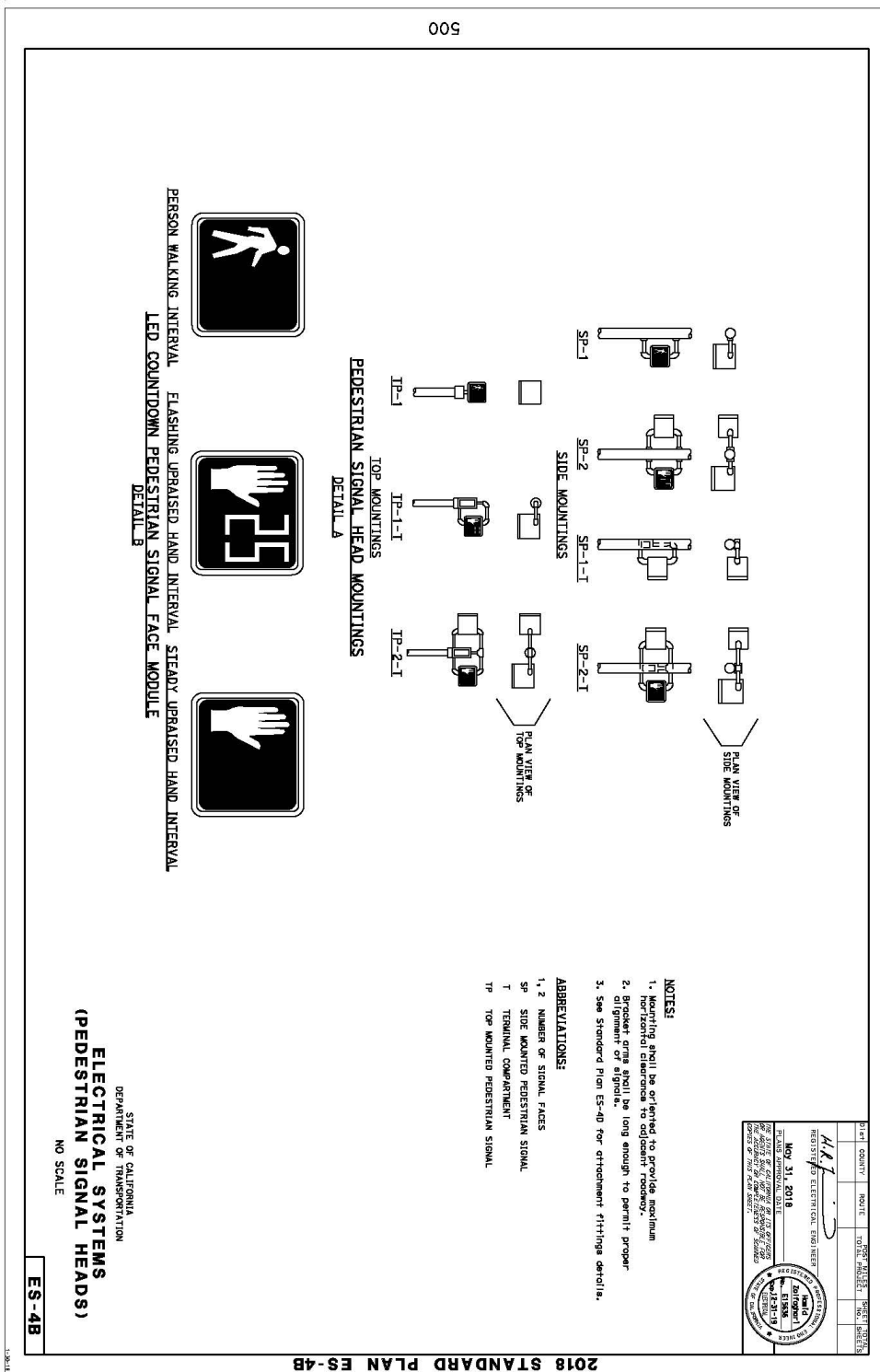




Figure 24 C



*Return to Table of Contents*

Figure 30 A

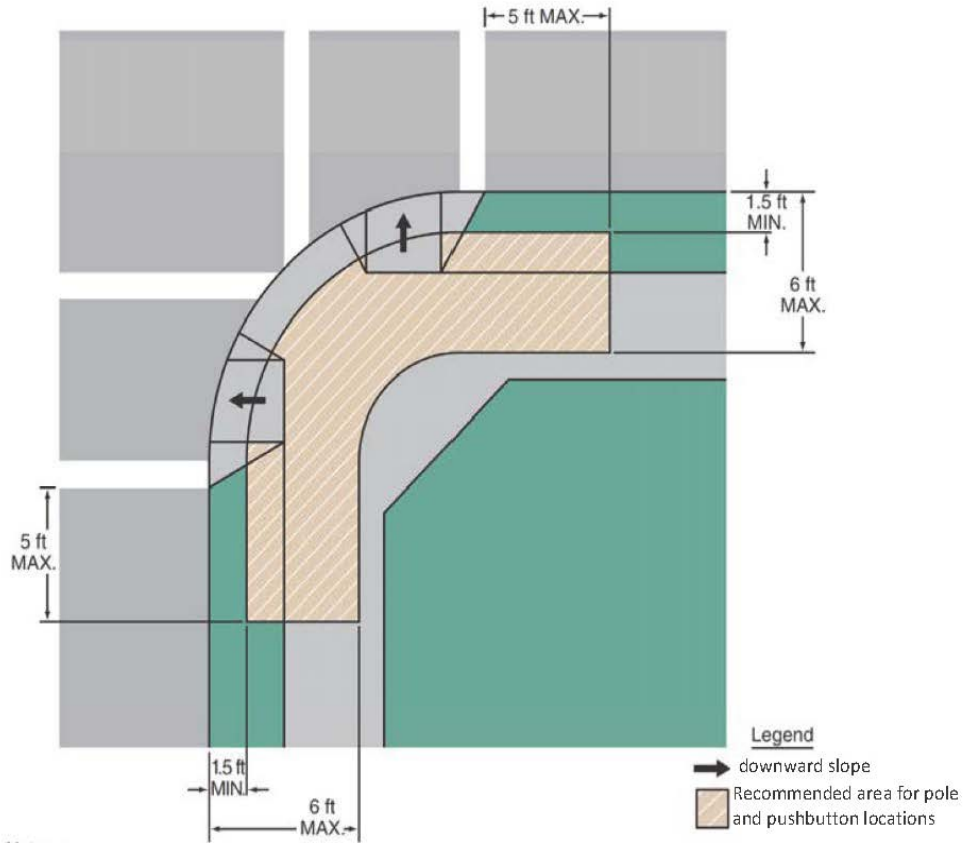


Figure 30 B

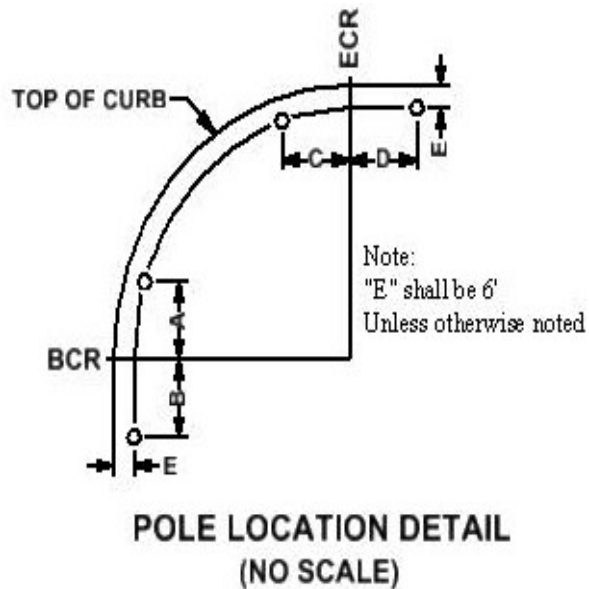


Figure 32 A

ANG SIZE WIRE OR CABLE TYPE		STD	PHASES	CONDUIT SIZE AND RUN NUMBER																			
				1	2	3	4	5	6	7	8	9	10	11	12	13	14	15	16	17	18	19	20
12 WIRE CONDUCTOR CABLE 11-#4 1-#12	(A)	#2, #5	-	1	1	1	-	-	-	-	-	-	-	-	-	-	-	-	-	-	-	-	-
	(B)	#4, #8	-	1	1	-	-	-	-	-	-	-	-	-	-	-	-	-	-	-	-	-	-
	(C)	#4	-	1	1	-	-	-	-	-	-	-	-	-	-	-	-	-	-	-	-	-	-
	(D)	#1, #2	-	1	1	-	-	-	-	-	-	-	-	-	-	-	-	-	-	-	-	-	-
	(E)	#1, #6	-	1	1	-	-	-	-	-	-	-	-	-	-	-	-	-	-	-	-	-	-
	(F)	#4, #8	-	1	1	-	-	-	-	-	-	-	-	-	-	-	-	-	-	-	-	-	-
	(G)	#8	-	1	1	-	-	-	-	-	-	-	-	-	-	-	-	-	-	-	-	-	-
	(H)	#5, #6	-	1	1	-	-	-	-	-	-	-	-	-	-	-	-	-	-	-	-	-	-
	<b>TOTAL CABLES</b>				8	8	2	2	2	1	4	3	2	1	1	1	1	1	1	1	1	1	1
	#6	SIGNAL SERVICE			-	-	-	-	-	-	-	-	-	-	-	-	-	-	-	-	-	-	3
#8	LUMINAIRE			-	2	2	2	2	2	2	2	2	2	-	-	-	-	-	-	-	-	-	
#10	LUMINAIRE			-	-	-	-	-	-	-	-	-	-	-	-	-	-	-	-	-	-	-	
#10	VIDEO POWER			-	2	2	2	2	2	-	2	2	2	-	-	-	-	-	-	-	-	2	
Belden 8281	VIDEO CABLE			4	4	2	1	1	-	-	2	1	1	-	-	-	-	-	-	-	-	-	
CAT 5	BROADBAND CABLE			1	1	1	1	-	-	-	-	-	-	-	-	-	-	-	-	-	-	-	
<b>CONDUIT SIZES (INCHES)</b>				2-3"	2-3"	3"	3"	3"	3"	3"	3"	3"	3"	3"	2"	-	2"	3"	3"	2"	-	2"	2"

CONDUCTOR SCHEDULE IS FURNISHED AS AN INSTALLATION GUIDE ONLY. IT SHALL BE THE CONTRACTOR'S RESPONSIBILITY TO PROVIDE THE CORRECT CONDUCTORS REQUIRED FOR THE INTENDED OPERATION.  
 ALL CONDUITS ARE EXISTING  
 ALL CONDUCTORS AND WIRING ARE NEW.

Figure 48 A

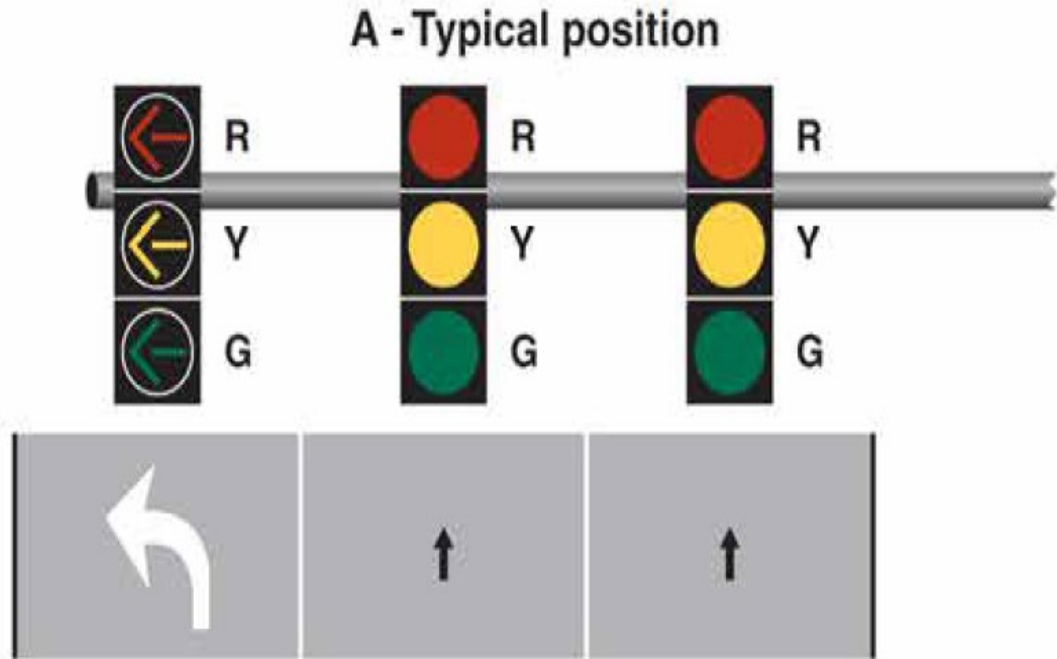


Figure 50 A

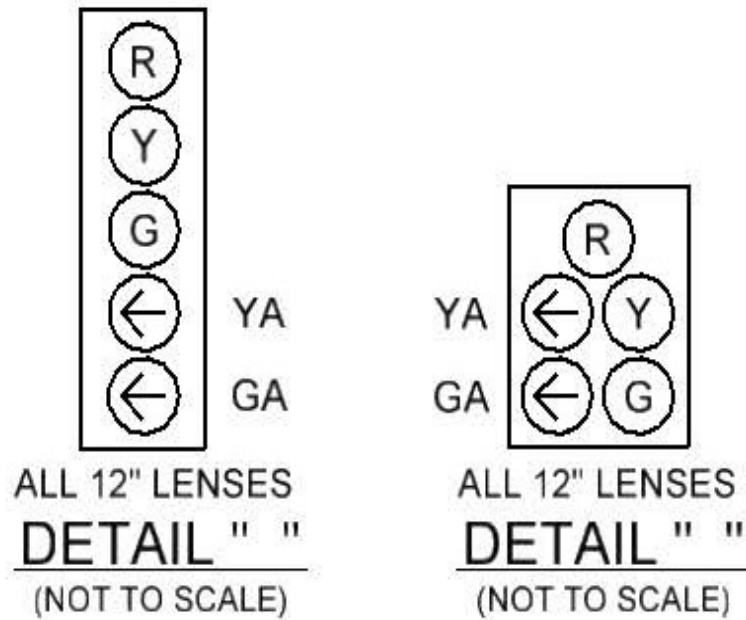


Figure 51 A

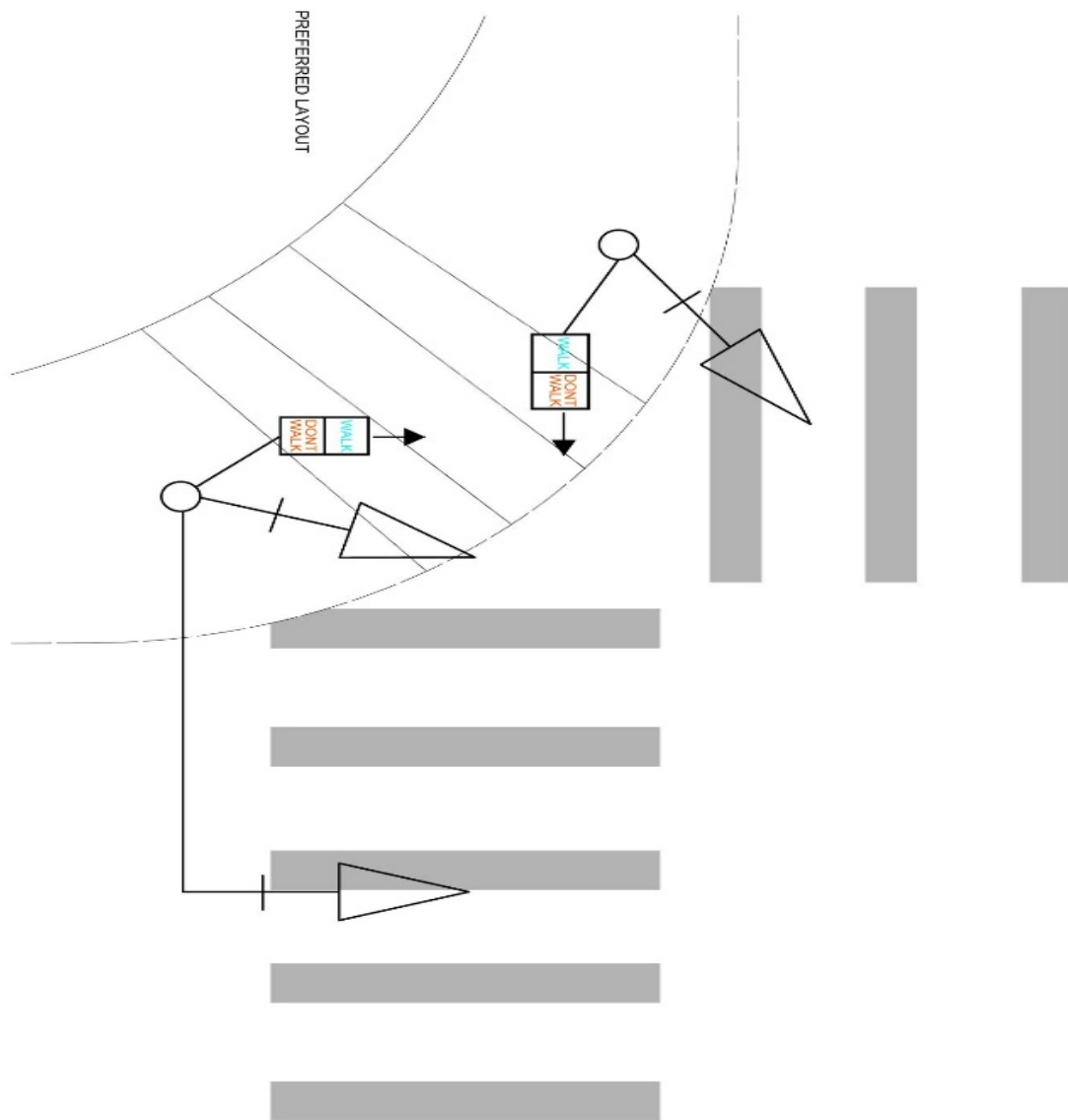


Figure 51 B

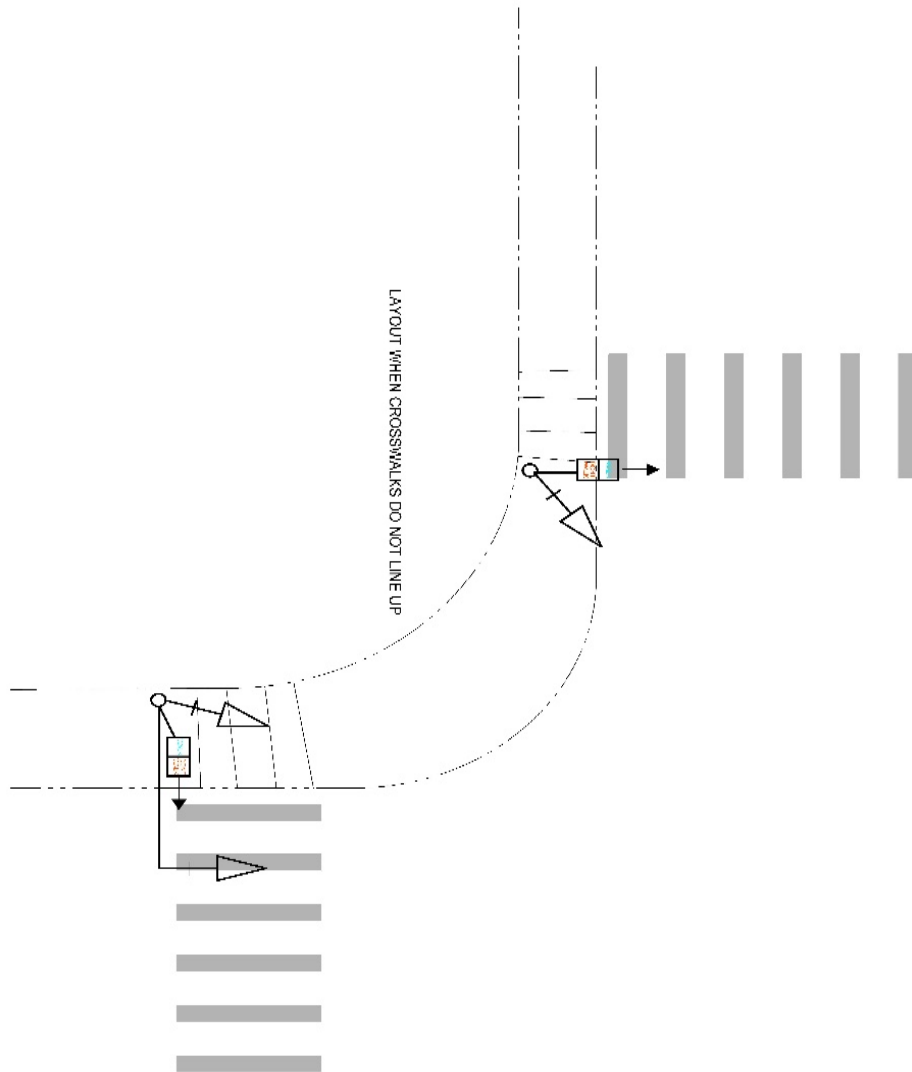


Figure 58 A

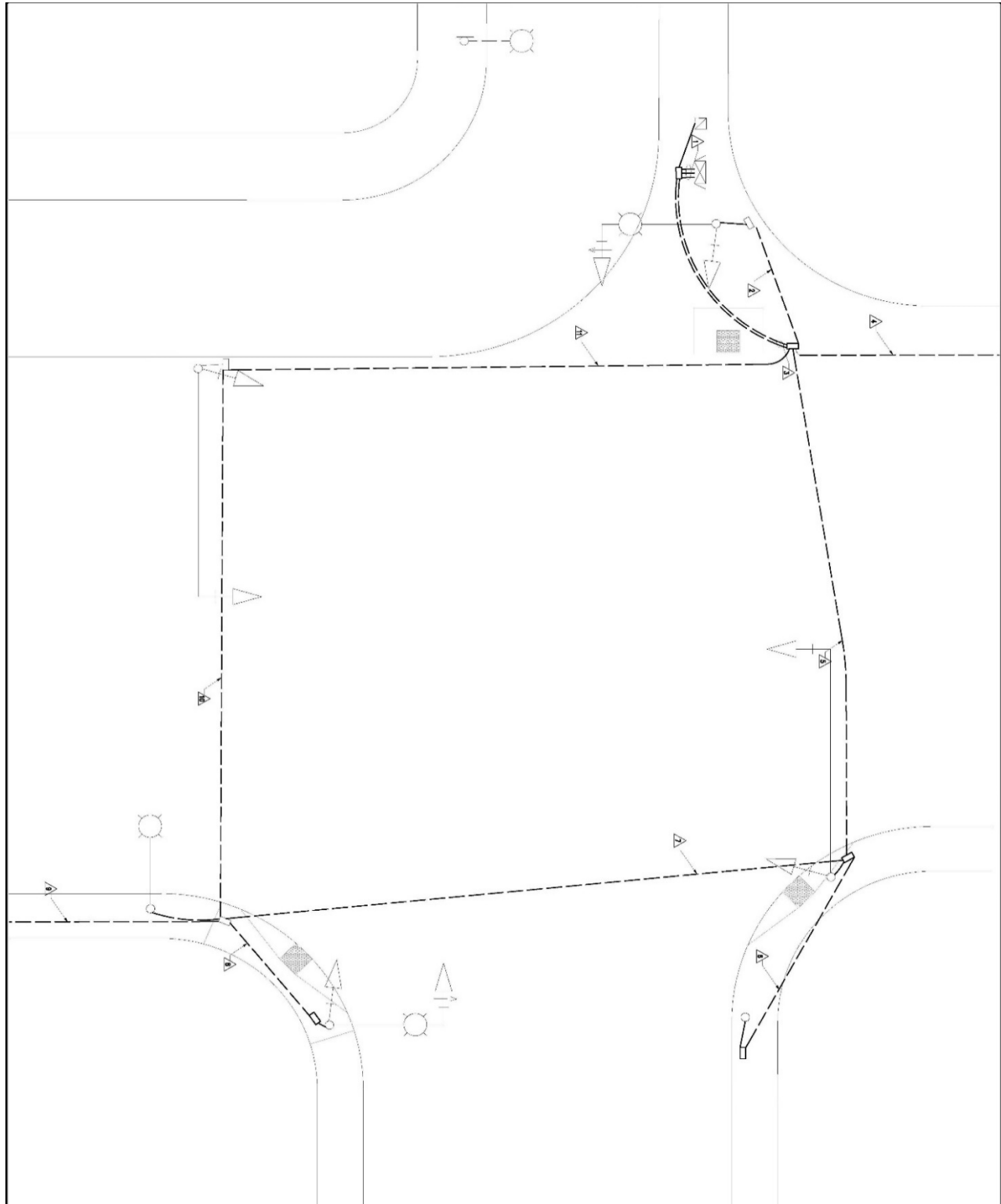


Figure 64 A

## Sample construction notes

- 1 EXISTING MODEL 332 CABINET WITH MODEL 2070 ATC CONTROLLER ASSEMBLY. CONNECT NEW WIRING IN CONTROLLER CABINET FOR INTENDED OPERATION PER PHASE DIAGRAM
- 2 REMOVE EXISTING SIGNAL HEAD
- 3 INSTALL NEW SIGNAL HEAD PER DETAIL A.

## Call out box with leader

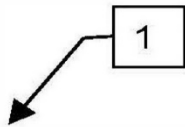


Figure 64 B

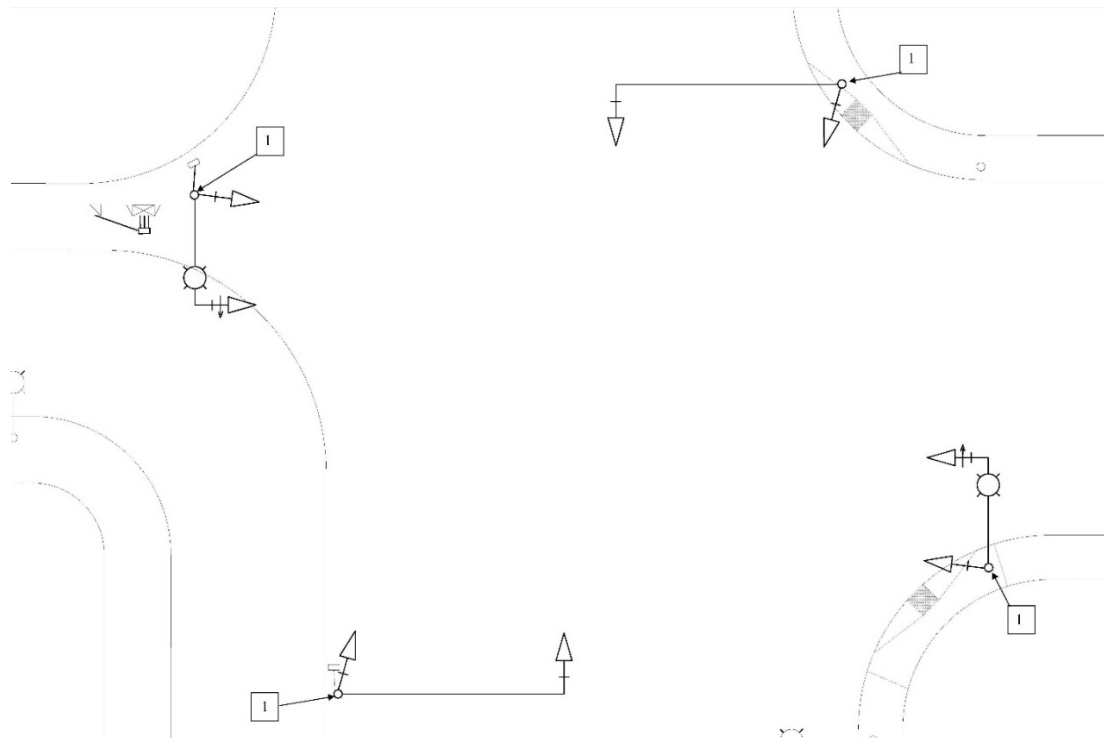
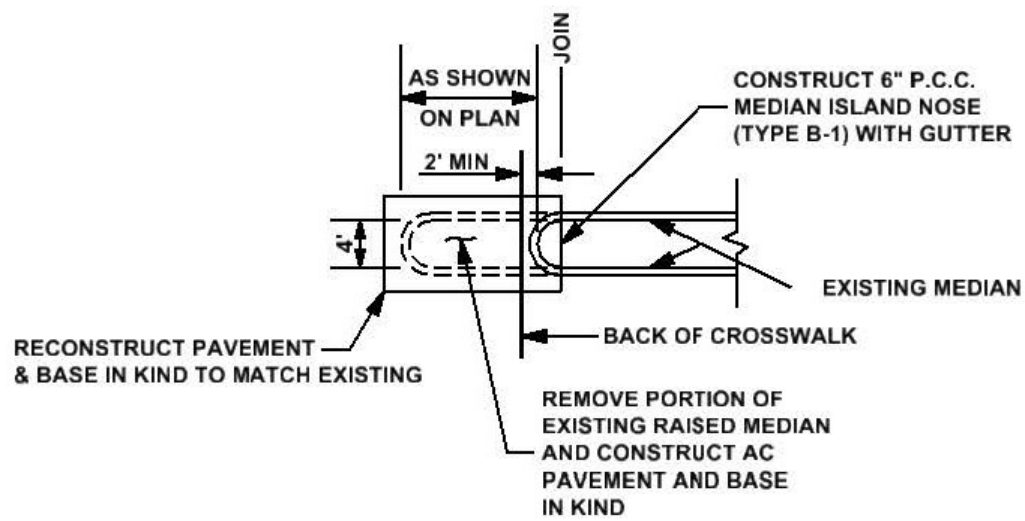


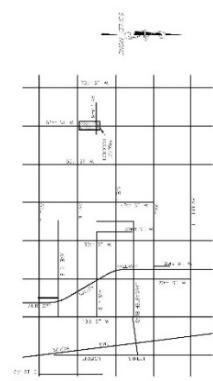
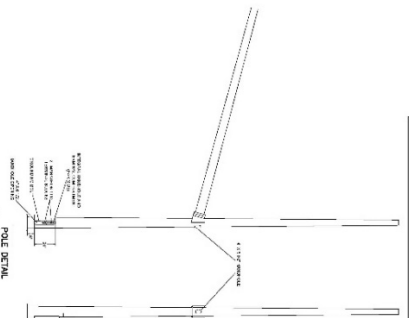
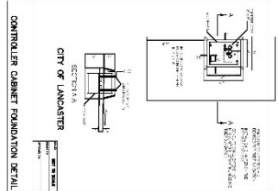



Figure 72 A



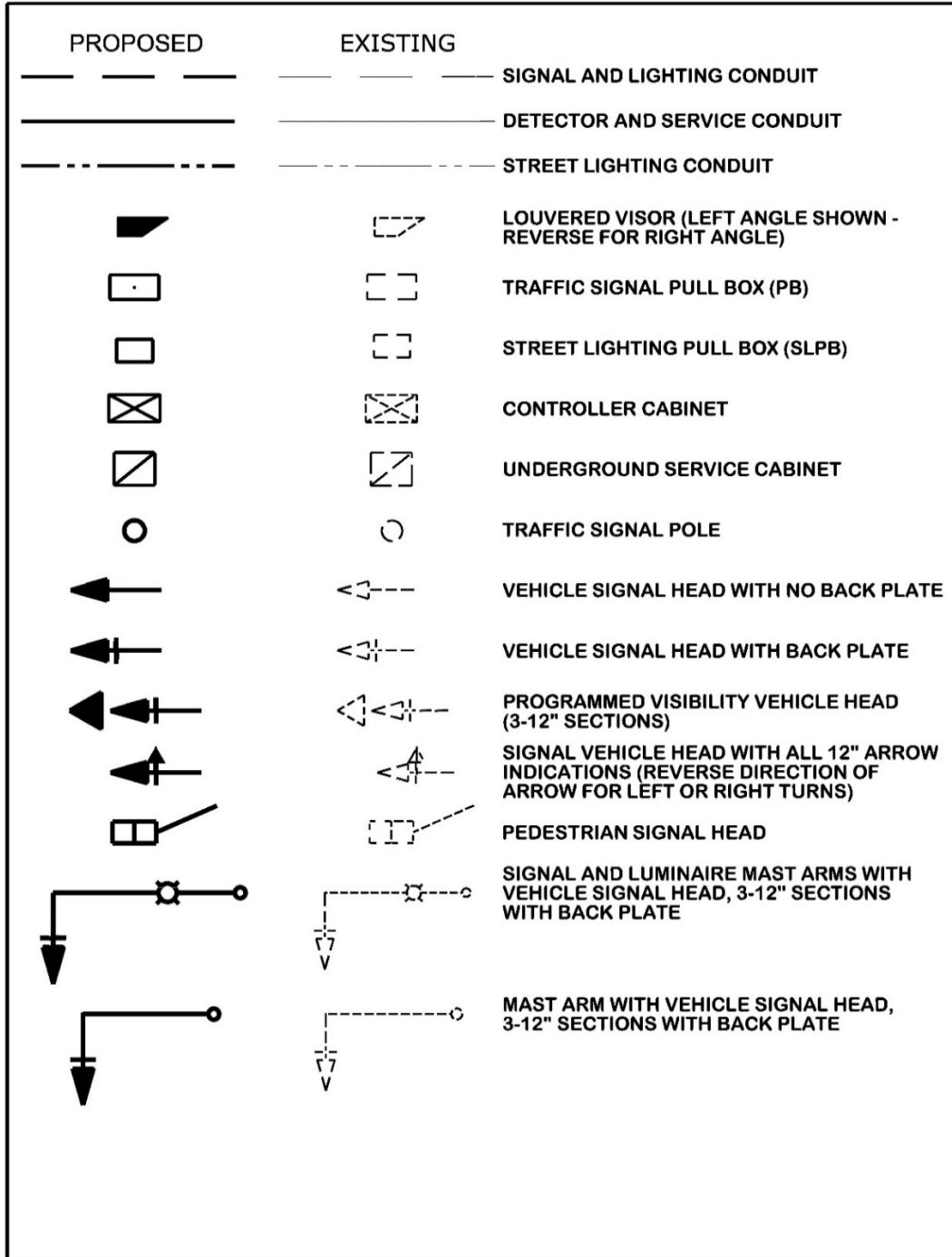
**DETAIL " "**  
**(NO SCALE)**


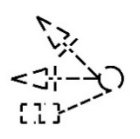

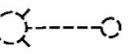

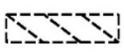

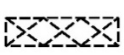















Sample Title sheet












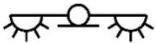




<p>GENERAL NOTES: ADD GENERAL NOTES HERE</p>	<p>SECTION REVISIONS: ADD SECTION REVISIONS HERE</p>	<h1 style="margin: 0;">SAMPLE PLAN</h1> <h2 style="margin: 0;">CITY OF LANCASTER</h2> <p style="margin: 0;">NAME OF PROJECT AND PROJECT NUMBER</p> <p style="margin: 0;">TRAFFIC SIGNAL</p> <p style="margin: 0;">NAME OF STREETS MAJOR AND MINOR</p>
<p>SHEET INDEX</p> <p>SHEET 1 - TITLE SHEET</p> <p>SHEET 2 - SIGNAL PLAN</p> <p>VICINITY MAP</p>		<p>LEGEND:</p> <div style="border: 1px solid black; width: 100px; height: 50px; margin: 5px 0;"></div> <p>SEE LEGEND AND MEASUREMENTS TABLE</p>
		
		<p style="text-align: center;"><b>CITY OF LANCASTER</b></p> <p style="text-align: center;">PLAN</p> <p style="text-align: center;">TITLE SHEET</p> <p style="text-align: center;">SHEET X OF X SHEETS</p>
		<p>AS - BUILD BLOCK</p> <p>REVISIONS BLOCK</p>



Legend 1



PROPOSED	EXISTING	
		TRAFFIC SIGNAL POLE WITH VEHICLE SIGNAL AND PEDESTRIAN HEADS
		TRAFFIC SIGNAL POLE WITH LUMINAIRE MAST ARM
		RETRO-REFLECTIVE MAST ARM MOUNTED SIGN
		INTERNALLY ILLUMINATED MAST ARM MOUNTED SIGN
		INDUCTIVE LOOP DETECTOR
		BICYCLE LOOP DETECTOR
		VIDEO DETECTION CAMERA
		VIDEO DETECTION ZONE
		WIRELESS RADIO ANTENNA
		FLASHING BEACON
		MANHOLE
		FIRE HYDRANT

PROPOSED	EXISTING	
		TELEPHONE POLE
		POWER POLE
		STREET LIGHTING POLE
		UTILITY VAULT
		RAILROAD CROSSING SIGNAL
		RAILROAD BEACON
		DEADMAN
		GUY POLE